

# **AMIAD Fertilizer & Chemical Injectors**

## **4-01, 4-02**

## **Installation, Operation and Maintenance Instructions**

Ref: 910101-000119/07.2012

Page 1 of 28

## PLEASE READ THIS

A few do's and don'ts to help you get the best out of your injector:

### ALL INJECTORS

- DO** read the manual carefully before using the Injector. The Injector is quite simple to operate and maintain. The manual will show you how.
- DO** check your water drive filter mesh element from time to time. Blocked filters are the commonest cause of "**injector malfunction**". Your drive water may not be as clean as you think.
- DO** wash out the injector after use by injecting some clean water (5-8 liters). This prevents crystallization inside the pump unit and subsequent scouring of the injector body.
- DO** thoroughly dry the motor and pump assembly before greasing.

### SUCTION TYPE ONLY

- DON'T** **pour a bag of solid fertilizer into the container on top of the suction head.** Prepare the solution before putting the suction head into the liquid fertilizer tank. This will prevent the cutout operating; pump cavitations and sucking abrasive particles, such as sand and fertilizer crystals into the pump.
- DO** rinse out your chemical solution container. Small abrasive particles (often found in solid fertilizers) may have settled below the top of the suction head base plate. Sucking these into the pump will cause excessive pump seal wear and scouring of the housing.
- DO** make sure the suction head is standing upright, otherwise the ball and the automatic cut out operation will not work properly.
- DON'T** position the injector lower than the level of solution in the container, thereby preventing the solution from draining through the injector into empty mains.

### CHEMICAL DOSING

It is highly recommended to use AMIAD flow regulator set for proper and precise fertilizer dosing.

Hand regulation is also possible, in which case; only use a chemical resistant Ball Valve with a stiff action or other type of hand valve with a locking device.

Variations in chemical flow are to be expected when regulating by hand valve.

## TABLE OF CONTENTS

<b>CONTENTS</b>	<b>PAGE</b>
Introduction and Applications.....	4
Features & Technical Data .....	5
General Description .....	6-7
Installation and Operation .....	8-10
Optional Accessories .....	11-15
Maintenance .....	16-17
Trouble Shooting .....	18-20
Parts Catalogue.....	20

## CHEMICAL INJECTION RATE FORMULA

- 1. Metric** Count the number of pulses in **30 seconds** and multiply by **4**. This will give the rate of injection liters/hour.  
 Ex: 42 pulses in 30 seconds x 4 = 168 liters/hr
- 2. U.S.A** Count the number of pulses in **32 seconds**. This will give the rate of injection in U.S.A. gallons per hour.  
 Ex: 45 pulses in 32 seconds = 45 US.gph
- 3. U.K.** Count the number of pulses in **26 seconds**. This will give the rate of injection in imperial gallons per hour.  
 Ex: 36 pulses in 26 seconds = 36 Imp.gph

**Amiad** products undergo constant quality control monitoring. The manufacturer reserves the right to incorporate changes and improvements in the products without prior notice.

## INTRODUCTION

The fertilizer and chemical injector needs no external power supply, since the linear hydraulic motor contained within the unit, is powered by the hydraulic pressure of the irrigation system.

The unit is resistant to nearly all known chemicals used in agriculture and horticulture.

### Injector Types

There are 4 types of fertilizer injectors:

- a) Suction pump type 4-01 (Cat. No. **300000-000011**) with suction head at the end of the suction pipe. Suitable for working with fertilizer tanks of less than 1 m<sup>3</sup>.
- b) Gravity feed type 4-02 (Cat. No **300001-000011**) fitted with a 1" C filter at the end of the suction pipe. Suitable for working with large fertilizer tank – which has an outlet at the bottom.  
Changeover conversion kits are available for converting from one type to the other.
- c) Duplex fertilizer injection type 4-03 (Cat. No. **300002-000011**) for large quantities of fertilizer 100-600 l/h. Fitted with suction or gravity feed heads.  
The duplex pump is constructed from two pumps mounted on a single stand and uses common pipes.

Fertilizer injector for automatic control (type **300000-000007**, **300001-000004**). For controlling the injector by computer, dozer or any other electronic control system.

### Applications

The unit can be used with the following types of chemicals.

#### **Agriculture:**

Fertilizers, Herbicides, Insecticides, Fungicides, Soil Saturants, Trace Elements, Nutrient Solution, Acids (for desolating drip systems), etc.

#### **Industry and Others:**

Water Treatment, De-scalants, Flocculants, Sterilants, Concentrates, etc.

## FEATURES

1. Easy control of injection rate
2. Easy control of total quantity to be injected.
3. Needs no outside energy
4. No need to install a throttle hand-valve in the mains in order to create pressure differential.
5. Suction model operates from open or closed chemical container.
6. Will inject into any diameter mains.
7. Wide range of injection (9-320 l/hr 2.4-70 US.gph).
8. Non-corrosive to nearly all types of chemicals used in irrigation and water treatment.
9. Cut-out in suction model operates automatically when chemical is exhausted.
10. Operation can be stopped automatically or manually.
11. Constant injection rate maintained throughout the cycle.
12. Light and mobile (Gross weight 5 kg – 11 lb).
13. Supplied with all parts, except for a length of 25 mm O/D plastic exhaust hose.
14. Stops operating if the mains pressure drops below 0.5 bar (7psi).
15. Chemically resistant Flow Regulators easily inserted into injector line.
16. Can be linked to electronic control panels.

## TECHNICAL DATA

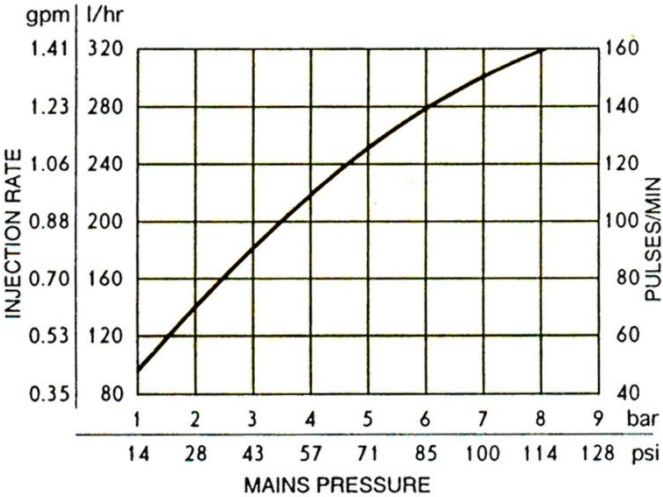
Injection rate	10 to 320 L/Hr	2.4 to 70 U.S. gph																																								
Working pressure	0.5 to 8 bar	7 to 112 psi																																								
Water consumption	3 times the quantity of chemical injected																																									
Gross weight	4 kg.	11 lb																																								
Materials	High grade engineering plastics. Parts in contact with chemicals are non-corrosive to most chemicals. Seals – Viton, Nitrile Rubber or Polyurethane																																									
Performance curve	 <p>The graph plots Injection Rate against Mains Pressure. The left y-axis shows Injection Rate in gpm (0.35 to 1.41) and l/hr (80 to 320). The right y-axis shows PULSES/MIN (40 to 160). The bottom x-axis shows Mains Pressure in bar (1 to 9) and psi (14 to 128). The top x-axis shows Mains Pressure in bar (1 to 9). A solid line represents the performance curve, showing a linear increase in injection rate with increasing mains pressure.</p> <table border="1"> <caption>Performance Curve Data</caption> <thead> <tr> <th>Mains Pressure (bar)</th> <th>Mains Pressure (psi)</th> <th>Injection Rate (gpm)</th> <th>Injection Rate (l/hr)</th> <th>Pulses/Min</th> </tr> </thead> <tbody> <tr> <td>1</td> <td>14</td> <td>0.35</td> <td>80</td> <td>40</td> </tr> <tr> <td>2</td> <td>28</td> <td>0.53</td> <td>120</td> <td>60</td> </tr> <tr> <td>3</td> <td>43</td> <td>0.70</td> <td>160</td> <td>80</td> </tr> <tr> <td>4</td> <td>57</td> <td>0.88</td> <td>200</td> <td>100</td> </tr> <tr> <td>5</td> <td>71</td> <td>1.06</td> <td>240</td> <td>120</td> </tr> <tr> <td>6</td> <td>85</td> <td>1.23</td> <td>280</td> <td>140</td> </tr> <tr> <td>7</td> <td>100</td> <td>1.41</td> <td>320</td> <td>160</td> </tr> </tbody> </table>		Mains Pressure (bar)	Mains Pressure (psi)	Injection Rate (gpm)	Injection Rate (l/hr)	Pulses/Min	1	14	0.35	80	40	2	28	0.53	120	60	3	43	0.70	160	80	4	57	0.88	200	100	5	71	1.06	240	120	6	85	1.23	280	140	7	100	1.41	320	160
Mains Pressure (bar)	Mains Pressure (psi)	Injection Rate (gpm)	Injection Rate (l/hr)	Pulses/Min																																						
1	14	0.35	80	40																																						
2	28	0.53	120	60																																						
3	43	0.70	160	80																																						
4	57	0.88	200	100																																						
5	71	1.06	240	120																																						
6	85	1.23	280	140																																						
7	100	1.41	320	160																																						

## GENERAL DESCRIPTION (FIG.1)

a. Reciprocating water motor & pump assembly (Part No. 19)	The reciprocating type motor in the cylinder housing (No.20) consists of two pistons and a main pilot valve. The pump, which is connected to the motor body, draws the chemical from the tank or container and injects it into the main pipeline.
b. Housing (Part No. 20)	The housing, to which the injection accessories are connected, Contains the motor and pump.
c. Automatic cut-out (Part No. 11)	The start-stop knob (No.12) us an integral part of the automatic Cut-out unit. The cut-out automatically stops operation of the pump, when the level of the chemical drops below the level of the suction head base (No.16). The automatic cut-out is only operational with Suction Type 4-01.
d. Valves (Parts No. 8,4,6)	Two valves are fitted into the discharge line and one valve is mounted on the chemical intake line. Their functions are to prevent water in the main line from entering the chemical tank and to prevent the return discharge of chemical into the tank or container.
e. Air-Release valve (Part No. 5)	This is a manually activated ball valve for venting air from the system, generally, during the initial operation. If as a result of a water stoppage, sub-pressure is formed in the main line, the ball in the Air-Release valve will automatically open the escape vent and the line will be vented into the atmosphere. This arrangement ensures that siphoning of the Air-Release valve is available to be used with sequential and automatic operations.
f. Suction Head (Parts Nos. 16-18)	The suction head consists of a weighted, round base plate (No.16) And filer (No.17) containing a plastic ball (No.18). The Suction Head is only supplied with the suction type 4-01 (Cat. No. <b>300000-000011</b> ).

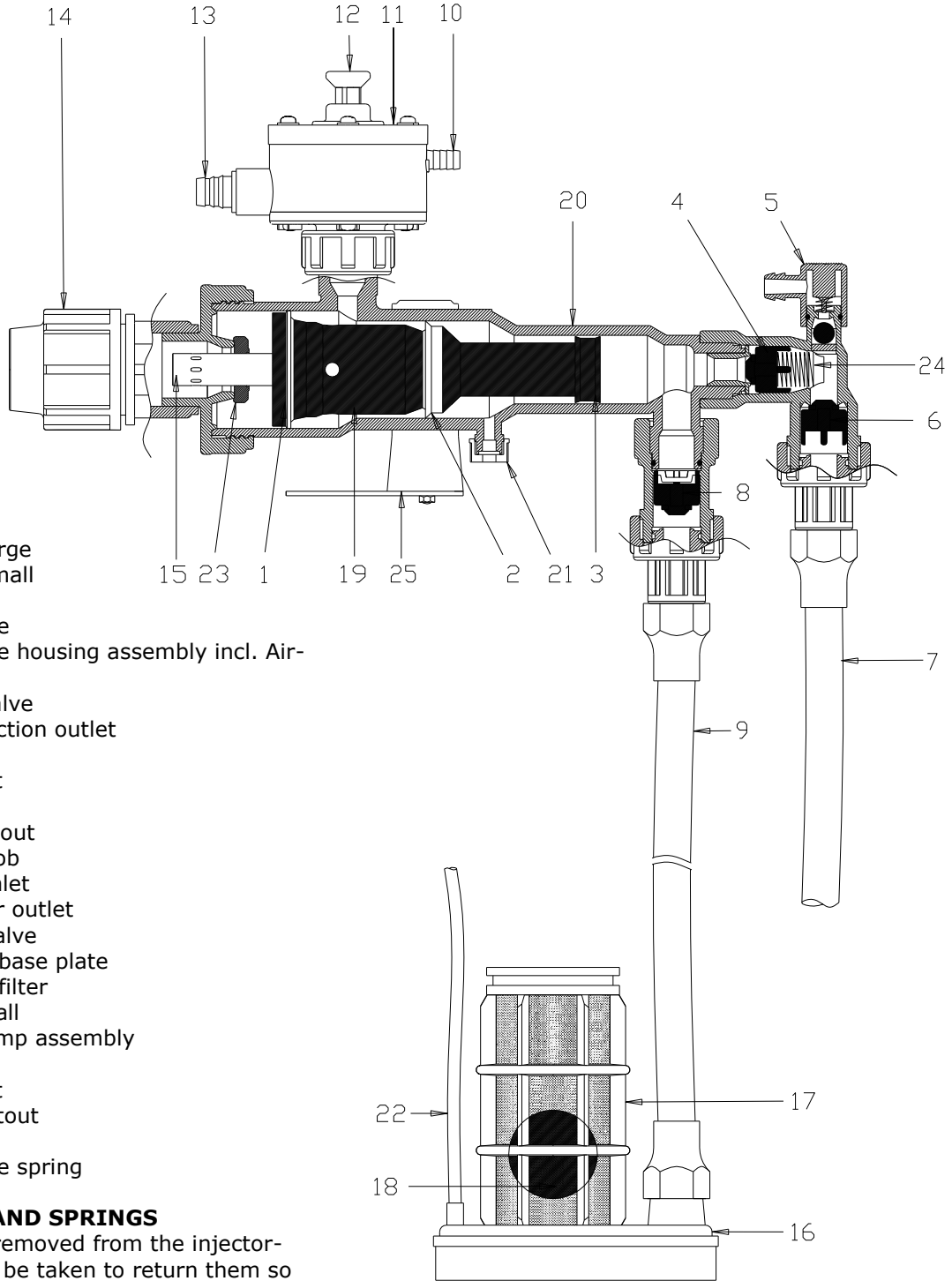

**KEY:**

- 1. Motor seal, large
- 2. Motor seal, small
- 3. Pump seal
- 4. Injection valve
- 5. Injection valve housing assembly incl. Air-Release valve
- 6. Non-return valve
- 7. Chemical injection outlet
- 8. Inlet valve
- 9. Chemical inlet
- 10. Pilot line inlet
- 11. Automatic cutout
- 12. Start-stop knob
- 13. Drive water inlet
- 14. Exhaust water outlet
- 15. Motor main valve
- 16. Suction head base plate
- 17. Suction head filter
- 18. Plastic float ball
- 19. Motor and pump assembly
- 20. Housing
- 21. Motor air vent
- 22. Pilot line – cutout
- 23. Bearing disc
- 24. Injection valve spring

**NOTE: VALVES AND SPRINGS**

If the valves are removed from the injector-special care must be taken to return them so they face the correct direction as in Fig. 1. Please note that only the Injection valve No.4 is fitted with a spring. Please take care when refitting the spring and be sure that it sits completely inside the four legs of the valve.

## PRELIMINARY PREPARATIONS FOR INSTALLATION

Types 4-01 (300000-000011) & 4-02 (300001-000011)

### **WARNING**

UNDER NO CIRCUMSTANCES IS A WATER SYSTEM, CONTAINING OR HAVING CONTAINED CHEMICALS, BEING DIRECTLY CONNECTED TO A DRINKING WATER SYSTEM.

THE MANUFACTURER WILL NOT BE RESPONSIBLE FOR INCORRECT ASSEMBLY OR MISUSE OF THE INJECTOR.

It is highly recommended to install the water drive hand-valve **after main filtration**. Before attaching the pump to the system, install two ¾" hand valves on the main water line. These valves must be located at least 50 cm apart. An upstream valve (1) will supply the drive water to operate the pump motor. A chemical solution will be injected into the system through valve (8) downstream.

Installation of the two filters, supplied with the pump, is indispensable for the protection of the valve assemblies and the pump motor. The first filter (3) (100 micron) in the drive water line prevents dirt and sand from entering the motor, thereby permitting smooth and steady operation. The second filter (5) (300 micron) in the chemical suction or feed line, prevents particles from entering the valve assemblies and jamming them in an open or closed position.

The installation of a check valve, in the mains between the two hand valves, is advisable. This will prevent circulating chemical-laden water operating the pump.

A length of 25 mm O/D (3/4" I/D) thin-walled plastic pipe should be fitted to the injector exhaust outlet (9), in order to lead away the exhaust drive water to a convenient place. The exhaust pipe should not be restricted and it should be installed level or downwards.



## INSTALLATION AND OPERATION

### SUCTION TYPE 4-01(300000-000011) INJECTION FROM CONTAINER

**KEY:**

1. Drive water hand valve
2. End connector
3. Filter
4. Automatic cut-out
5. Suction head
7. Air-release valve
8. Injection line hand valve
9. Water exhaust
10. Check valve (optional)

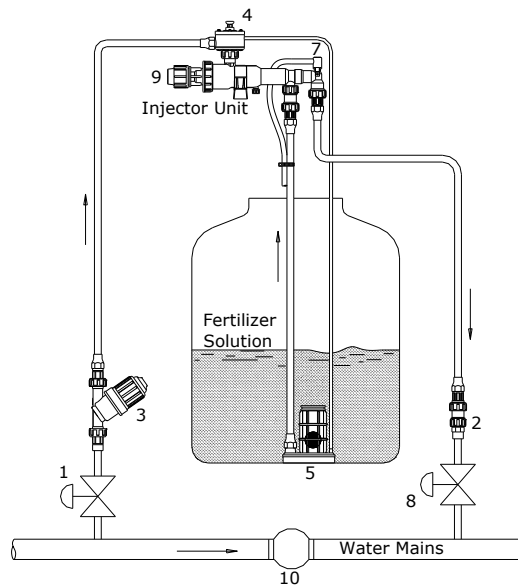

- a. Hang the pump, with the sling provided, at a convenient height on a post made of 1" galvanized pipe. Do not hang it below the solution level of the container.
- b. Connect the drive water line (through the 1" filter supplied) to the mains by means of the union coupler.
- c. Connect the injection line by means of the second union coupler downstream from the drive water coupler.
- d. Place the suction head in the chemical container and ensure that it stands upright.
- e. Fully open the hand valve between the injection line and the main water line.
- f. Open the drive water hand valve and pull out the knob on the automatic cut-out. The motor will start operating.
- g. To prime the pump, press the air release valve cap until all the air is expelled and chemical is ejected from the air release valve. There will be reduction in the motor speed when the pump starts operating. If an automatic air release valve is fitted there is no need to prime the pump.
- h. The rate of chemical injected can be adjusted by throttling the injection line hand valve or by using flow regulators (see pages 12-14).

**NOTE:**

Suction type 4-01 (300000-000011) can be converted to Gravity Feed type 4-02 (300001-000011) by means of a conversion kit Cat. No. 700190-003307 Note that the kit does not include an NC Hydraulic cut-out.

**IMPORTANT:**

The suction type injector should be washed out after use, by placing the suction head in a container of clean water and pumping for 50-100 strokes.

## INSTALLATION AND OPERATION GRAVITY FEED TYPE 4-02 (300001-000011)

### KEY:

1. Drive water hand valve
2. Drive water filter
3. Chemical supply filter
4. Automatic cut-out (NC Hydraulic valve)
5. Anti-siphon valve
6. Air release valve
7. Injection line hand valve
8. Water exhaust
9. Check valve (optional)
10. End connector

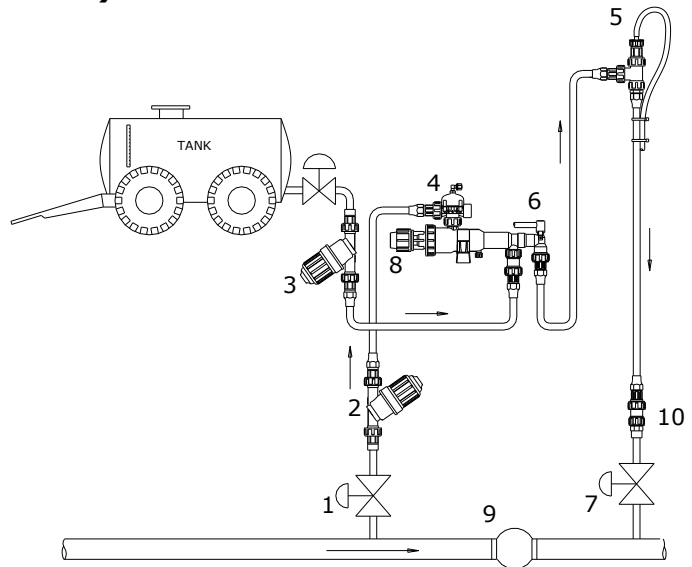

- a) The anti-siphon valve should be placed at a height above the surface of the fertilizer solution, with the valve outlet pointing upwards.
- b) Hang the pump on a 1" galvanized pipe post near the tank at a convenient height using the provided sling.
- c) Connect the chemical feed line to the tank by means of the union coupler supplied.
- d) Connect the end of the injection line to the closed chemical injection hand valve.
- e) Connect the drive water line (with the 1" C filter) to the water mains by means of the union coupler.
- f) Open the chemical tank outlet hand-valve.
- g) Open drive-water hand valve.
- h) When pressure is built up in the injection line, the anti-siphon valve closes and the pump will stop operating.
- i) Open the injection line hand valve on the irrigation mains and the pump will operate normally.
- j) There are two ways to connect the N.C. valve to the injector, depending on how it is to be used:
  1. When using the injector without a computer: The injector is ready for use (with constant pressure command to the N.C. Hydraulic valve). In this way operation is allowed without a computer or any controller.
  2. When operating with a computer/controller: Should the injector work with a computer or a controller, the side port of the N.C. valve should be plugged and a pilot tube from the controller solenoid should be connected to the command connector of the valve.
- k) The injection rate of chemicals can be adjusted by throttling the injection line hand valve or by using Flow Regulators (see pages 12-14), see injection formula at beginning of manual.

### **IMPORTANT:**

The Gravity-Feed type should be rinsed through by placing the chemical feed inlet (adjacent to the blue filter) in clean water and pumping as above.

## OPTIONAL ACCESSORIES

### FLOW REGULATORS

The injector can be operated at constant output, irrespective of pressure fluctuations in the main line, by inserting a Flow Regulator unit in the chemical injection line. Please see pages 12-14 for available flow rates and assembly instructions.

Available as optional extras: A wide range of extremely accurate chemical resistant flow regulators. The complete regulator assembly, containing an interchangeable color-coded flow regulator, is easily inserted between the two parts of the plastic union coupler in the chemical injection line.

The complete regulator assembly includes a Blue (130 micron screen) chemical resistant filter to prevent clogging of the Flow Regulator.

Assembly and installation instructions are supplied with every Flow Regulator.

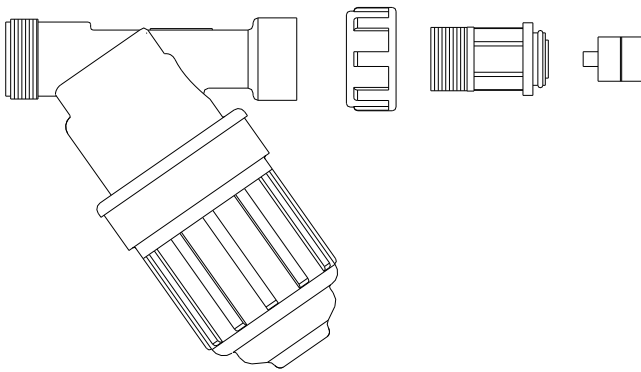

Quantity	Description	Cat. No.
1	SPARE PARTS KIT	<b>700190-003251</b>
1	Spare parts for injector valve assembly	<b>700190-003252</b>
1	Motor seals set for fertilizer injector – viton	<b>700190-003253</b>
1	O-ring set for fertilizer injector and filter	<b>700190-003254</b>
1	Motikot grease PG21	<b>760190-000127</b>

## FLOW REGULATOR WITH SUCTION TYPE INJECTOR 4-01(300000-000011)

### Assembly instructions:

1. Open the union coupler at the end of the chemical injection pipe. See pictures 1&2.
2. Connect the flow regulator filter to the injection pipe. Ensure the arrow on the filter is in the chemical flow direction (see picture 3).
3. Insert the flow regulator capsule into the empty check valve so the projection on the face of the capsule points towards the filter. (See picture 3).
4. Connect the flow regulator housing to the union coupler attached to the flow regulator filter. (See picture 4).
5. To change the capsule – open the union coupler containing the capsule. Slightly open the injector hand valve. The water line pressure will eject the capsule. Close the control valve, insert the capsule required and rejoin the union coupler.

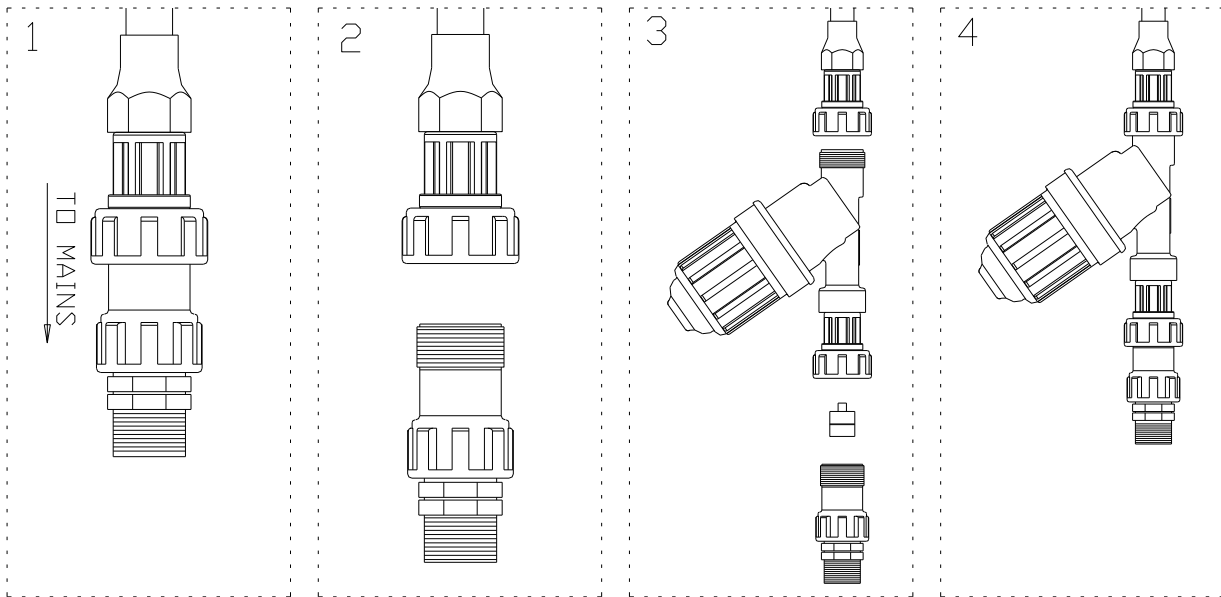
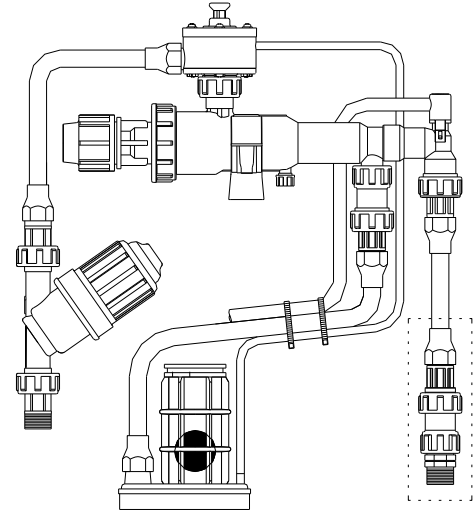

## FLOW REGULATOR WITH GRAVITY FEED INJECTOR 4-02 (300001-000011)

### Assembly instructions:

1. Open the check valve at the end of the chemical injector pipe. See picture 1.
2. Remove the valve installed from its place and insert into the inlet of the flow regulator filter. (See picture 3).
3. Connect the flow regulator filter to the injection pipe and make sure that the arrow on the filter is in the direction of chemical flow. (See picture 3).
4. Insert the flow regulator capsule into the empty check valve so the projection on the face of the capsule point towards the filter. (See picture 3).
5. Connect the flow regulator housing to the union coupler attached to the flow regulator filter. (See picture 4).
6. To change the capsule, open the union coupler that contains the capsule. Slightly open the injector hand valve. The water line pressure will eject the capsule. Close the control valve, insert the capsule required and rejoin the union coupler.

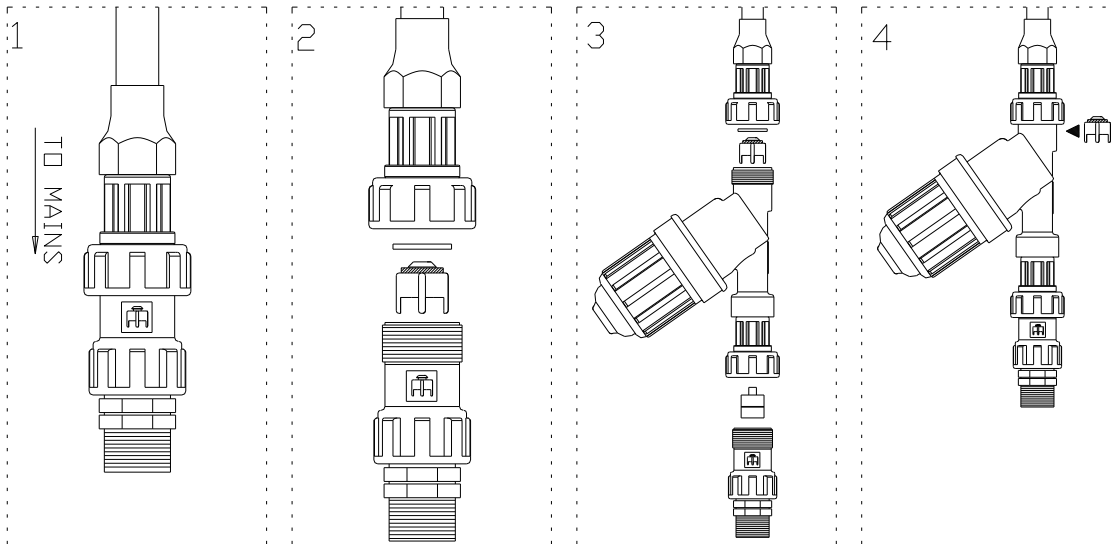
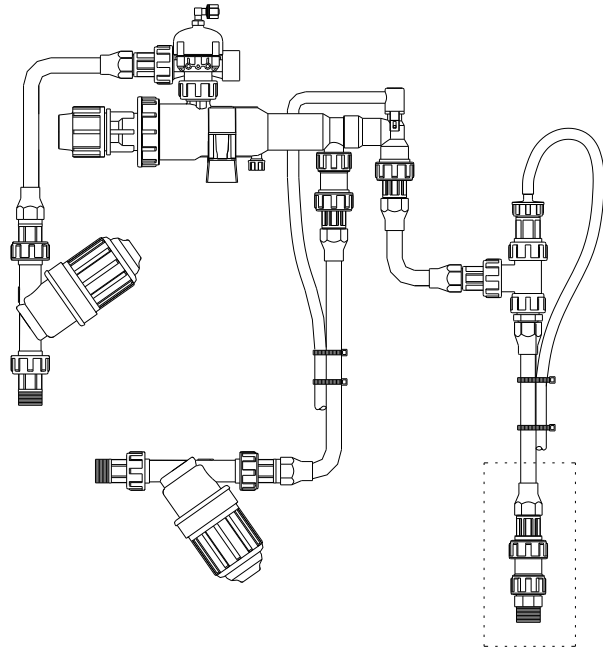

## 3/4" N.C. "NORMALLY CLOSED" HYDRAULIC VALVE (300004-000003)

**Wide variety of applications:** For chemical liquid fertilizer and water flow control.

**Fully chemical resistant:** Plastic components and viton seals guarantee corrosion-free operation with all liquid chemicals and water.

**Water or air operated pilot system:** The pilot system is completely separated from the valve itself thereby allowing the flow of expensive liquids to be controlled by pressurized water.

**No need for outside source of energy:** Operates from water mains supply.

**Valve closes with pilot pressure:** The "normally closed" feature ensures that if the pilot water pressure drops due to main pump shut-down to control system malfunction or pilot tube damage the valve will close automatically.

**Operates in high pressure systems:** Maximum working pressure up to 10 bars (140 psi)

**Choice of flow directions:** The valve can be installed with 1 inlet and 1 or 2 outlets or with 2 inlets and 1 outlet.

**Easy to install:** Simple installation by means of the Amiad union connector (Raccord). Unlimited number of valves can be screwed together forming a valve manifold.

**Wide range of uses:**

Control opening and closing of spraying and fertilizing systems.

Allocate liquid chemicals to spraying and spraying according to a pre-set command.

Allocate several liquids from different sources simultaneously to one or more outlets.

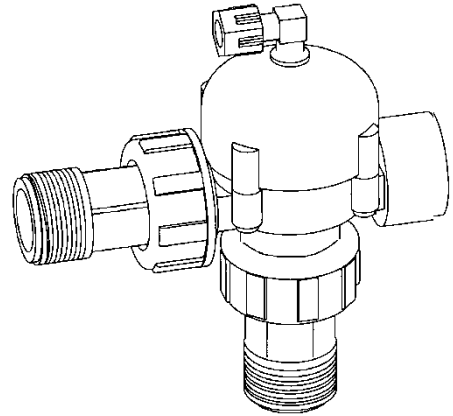

PRESSURE TABLE			
WORKING PRESSURE		PILOT PRESSURE	
m.	psi	m.	psi
10	14	4.5	6
40	57	9.0	13
80	114	14.0	20

PRESSURE LOSS TABLE				
FLOW RATE			PRESSURE LOSS	
l/m	Usgph	Imp.gpm	m.	psi
10	2.6	2.2	0.4	0.6
20	5.3	4.4	1.2	1.7
30	7.9	6.6	3.0	4.2

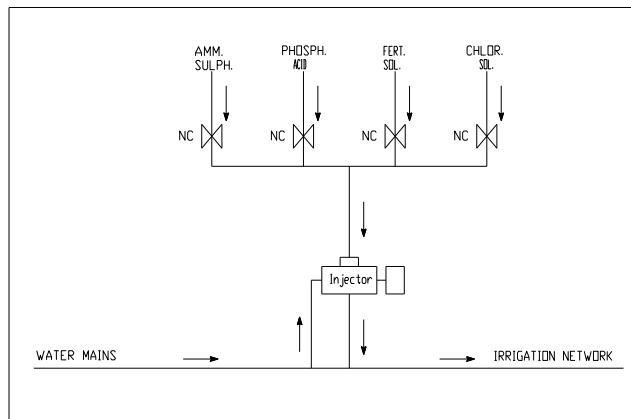
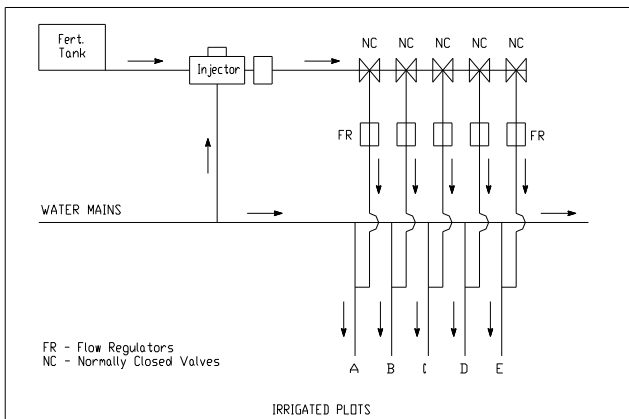

## AIR RELEASE VALVE

1. To release air from fertilizer system on initial start.
2. Prevent siphon suction after the fertigation finished by ventilating the system.

**It is recommended to periodically check that the valve moves freely in its seat. DO NOT install a spring under this valve.**

## INJECTOR CONTROLS

### **Injection flow rate**

The injection rate can be controlled by throttling the chemical injection hand control valve, for hand irrigation only, use a chemical resistant ball valve, with a stiff action or other type hand valve with a locking device.

Variations in chemical flow are to be expected when regulating by hand valve.

Chemical injection rate formulae are found on page 3 of this manual. Twice the number of pulses/min. Give the injection rate in liter/hr. Other formulae are given for flow rates in both imp. and U.S. gph.

### **Automatic dosage**

The total quantity of the injected chemical can be controlled in the following ways:

- a) For the Suction type only: Fill the container with the required amount of the chemical and place the suction head on the bottom of the container, or alternatively suspend the suction head in the container at such a height, so that the liquid above the base of the suction head, is the required quantity to be injected.
- b) The suction and gravity feed type: By installing a water metering valve to exactly 3 times the required quantity of chemical to be injected, Please note that this method is far from being accurate the water meter is not designed for pulse operation.
- c) Use an Irrigation computer for Dosage or Proportional Fertigation.

**NOTE:** When flow regulators are installed, method b) is not recommended.

## MAINTENANCE

It is recommended to replace the two motor seals, pump seal and bearing disc every season.

### NOTE:

To keep the pump in good working condition, it should be lubricated with the recommended grease every 200 hours or depending on frequency of use and water pressure.

### For the injector lubrication use industrial silicon white grease

- a. Stop pump operation by pressing the start-stop knob or close the hand-valve.
- b. When operating with gravity feed, close the chemical tank outlet hand-valve.
- c. Disconnect the exhaust pipe from the pump.
- d. Unscrew the cylinder housing cap. (See Fig. 9)
- e. Removing the cap will reveal the main control valve (a round rod with holes on the tip).
- f. Pull the valve gently. Pull out the start-stop knob or open the hand-valve (Fig.10). The drive water will eject the motor from the cylinder body.  
Press start-stop knob to stop the drive water or close the hand-valve.
- g. Thoroughly clean and dry the motor unit and then lubricate the tree seals with the Silicon grease provided
- h. Slide the motor back into the cylinder housing after emptying it of water. Take care that the Bearing Disc is returned with the colored side inwards.
- i. Screw on the body cap and reconnect the exhaust pipe to the pump. The pump is ready for operation.

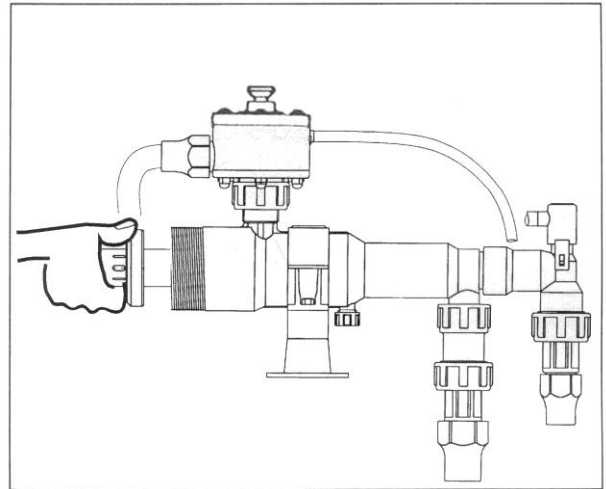

When replacing the pump seal – thoroughly dry and clean the pump seal seat before replacing.



## GREASING THE FERTILIZER INJECTOR

MOLIKOT PG-21 is advanced Silicon grease that was examined and found ideal for the lubrication Amiad Injectors.

Greasing the fertilizer injector is part of its routine standard maintenance requirements.

The frequency of the greasing depends on the drive water quality and pressure, the fertilizer quality and the injector mechanical condition.

The injector should be lubricated whenever reductions in its efficiency and /or friction noises are recognized.

### **Applying instructions:**

- 1) Clean and dry the injector piston.
- 2) Apply a thin layer of grease on all three piston seals as shown in the drawing.
- 3) Verify that the Injector Cylinder is clean.
- 4) Insert the lubricated piston into the cylinder, mind not to band the seal edge while pushing the piston into the cylinder.

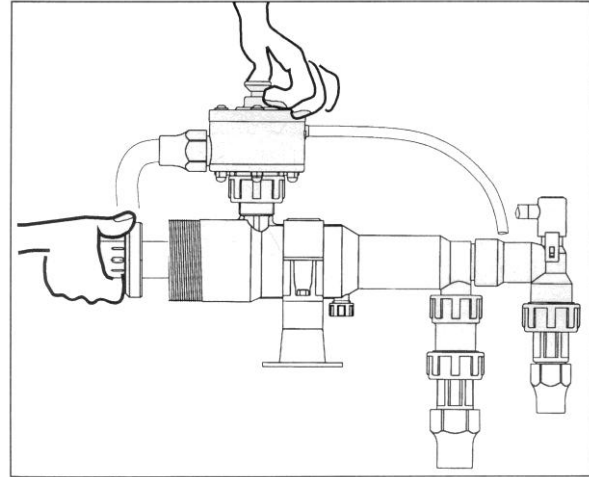

of

**Please use only MOLIKOT PG-21 for lubricating the injector pumps.  
A tube of grease can be found in each new injector box.**

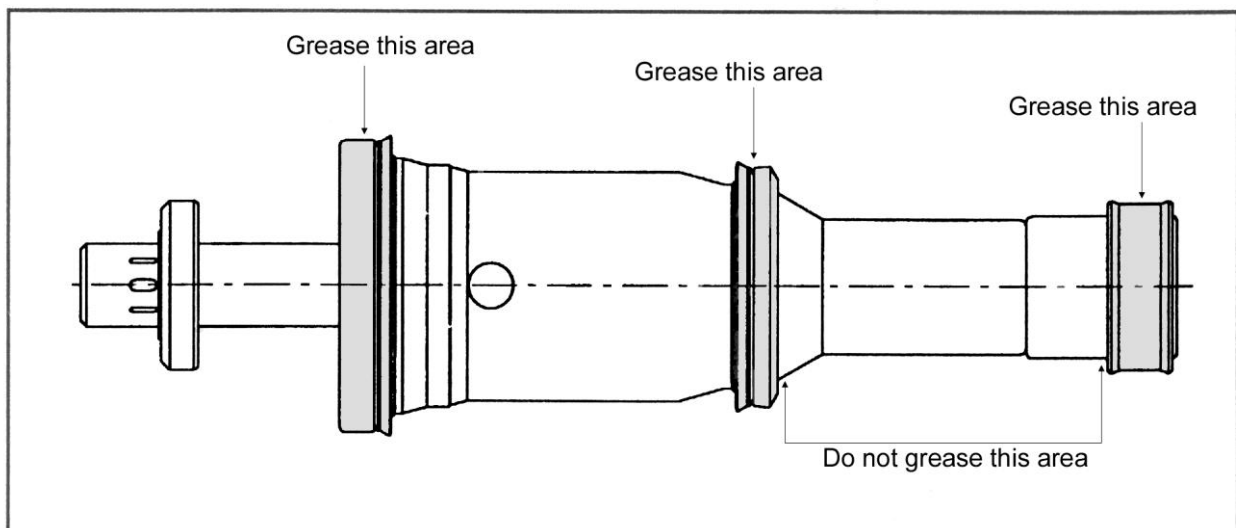

## TROUBLE SHOOTING

The following trouble shooting table will help you to locate and solve most of the trouble that may occur during fertigation.

The table is made of three columns.

- a. Fault-as they appear in the field
- b. Possible cause – there is more than one possible cause to a fault; the possible cause is marked by its probability.
- c. Checking & trouble shooting – explains how to find the fault and how to fix it step by step.

### Replacement parts:

Can be obtained in readymade sets of parts of a specific group (i.e. motor seal set)

FAULT	POSSIBLE CAUSE	CHECKING & TROUBLE SHOOTING
A. MOTOR		
1. Motor is not working	1. Drive water malfunction	Check opening of pump cutout, hand Regulating valve and/or water line.
		Check that the 155 mesh=0.1 mm filter on The drive water line is clean.
		Check that water reaches motor: a. Press star-stop knob b. Open cylinder housing cap. c. Take out motor and pump assembly (see Fig.10)
	2. Defective motor seals	Visually check condition of pump and motor Seals.
	3. Main motor valve jammed	Check movement of main control valve for smoothness, free forward and backward.
	4. Breaks or cracks	1. Visually check for breaks or cracks in assembly. 2. Empty cylinder housing and replace assembly with cutout closed. 3. Open drive water.
5. Restriction in the Exhaust Hose or Exhaust Hose installed upwards	1. Visually check Exhaust hose. 2. Press Air Release Valve – Pump operates by ejecting chemical through Air Release Valve. 3. Remove restriction and/or point Exhaust Hose downwards.	
6. Blockage in Chemical injection line	1. Press Air Release Valve 2. If Injection starts from the air release valve, check non-return valve, chemical line or injection line hand valve.	

<b>FAULT</b>	<b>POSSIBLE CAUSE</b>	<b>CHECKING &amp; TROUBLE SHOOTING</b>
2. Motor works slowly and with difficulty	1. Defective seal	Check assembly as above
	2. Mechanical interference in control valve movement	
	3. Seals lack grease	Lubricate pump and motor seals with recommended grease
	4. Drive water blockage	Check drive water and filter.
	5. Exhaust hose restricted	See A.1.5
3. Motor vibrates and works irregularly	1. Interface in suction system	1. Check if suction filter is clean 2. Check that suction head ball is not stuck in the base. 3. Check if the 25mm exhaust pipe is too long.

<b>FAULT</b>	<b>POSSIBLE CAUSE</b>	<b>CHECKING &amp; TROUBLE SHOOTING</b>
<b>B. PUMP &amp; VALVE SYSTEM</b>		
Motor works well but does not pump chemical after venting air via Air-release valve	1. Defective pump seal	Remove motor assembly and visually check the pump seal.
	2. Defective injection valve	Remove pipe from air-release and start pump; touch valve opening lightly. If suction is felt, injection valve is not working. Remove and check.
	3. Jammed or defective suction valve	Open inlet valve: a. Check smooth movement of valve b. Remove valve and visually check seals
	4. Gravity feed: Air in fertilizer injection line	Vent air as per operating instructions

<b>FAULT</b>	<b>POSSIBLE CAUSE</b>	<b>CHECKING &amp; TROUBLE SHOOTING</b>
<b>C. STOPPAGE – SUCTION PUMPING</b>		
1. Spring resistance on pressing start-stop knob which reopens by itself.	1. Air trapped in pilot tube to cutout.	1. Disconnect cutout pilot tube. Pressing knob will then stop flow. 2. After reconnecting pilot tube, check that there is no sag where water may collect and interfere with free airflow.
2. Cut-out closes although suction head immersed in liquid.	1. Clogged filter screen causing ball to drop on base vent.	1. Wash and clean filter screen.
	2. Viscous fluid cannot pass through screen causing ball to drop to base.	1. Change filter screen to larger perforation.

# PARTS CATALOG

## SUCTION HEAD ASSEMBLY – TYPE 4-01 (700190-003301)

Ref.	Description	Cat. No.
1	Suction base assembly	700190-003317
2	Plastic ball	770104-000186
3	Filter screen element, 50 mesh	710101-000512
5	Coupler for 20mm pipe	700190-003256
6	Pilot tube 6x10 (2.4 m.)	700190-003302
7	Toothed clamps x6	760108-000095
8	Connector 20mm	780101-000738
9	Suction pipe 1/2" (2 m.) incl. fitting	700190-003291

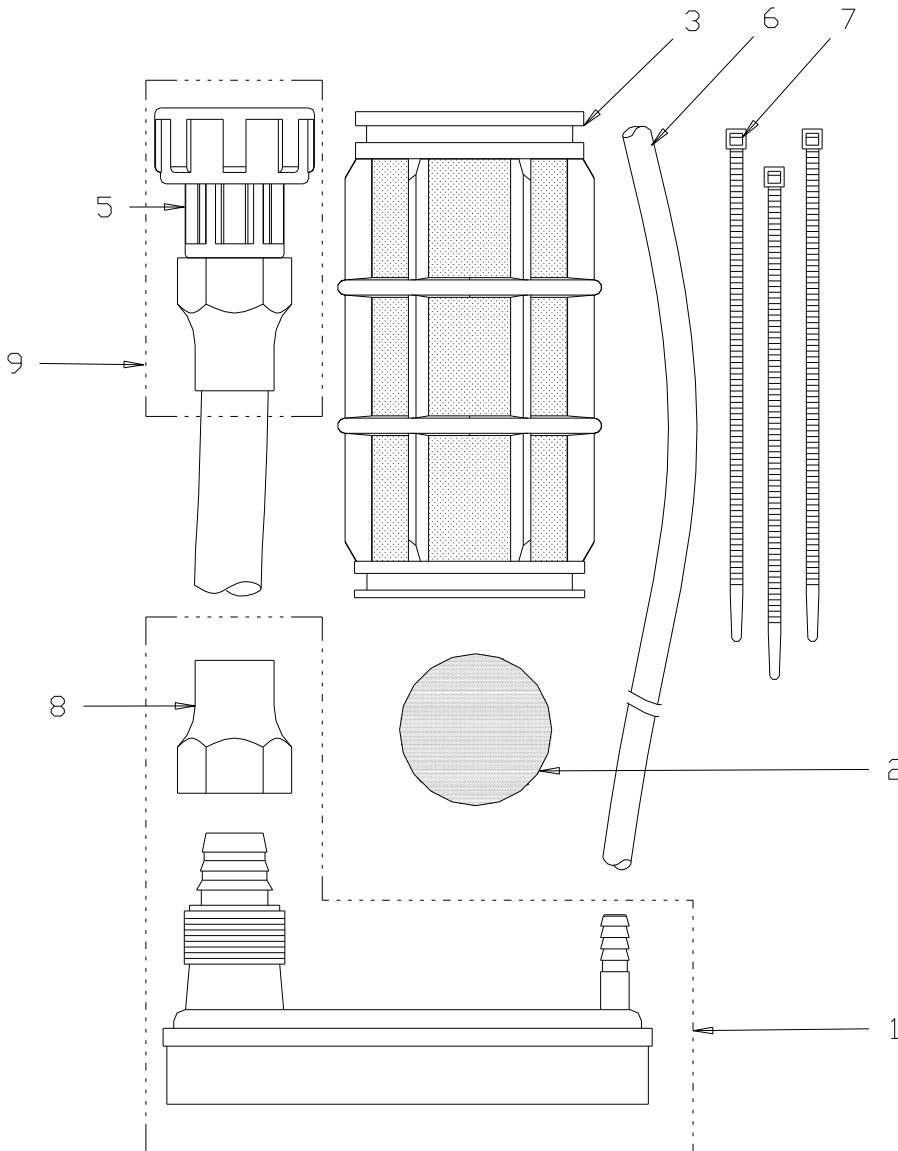

## DRIVE WATER PIPE & FILTER (4-01 & 4-02)

Ref.	Description	Cat. No.
1	Drive water pipe for 4-02	700190-003294
1	Drive water pipe for 4-01	700190-003296
2	1" C Filter, 100 micron (155 mesh)	011001-000001
3	Filter housing 3/4"	710101-000478
4	O-Ring (34 x 2.15)	770102-000099
5	Nylon screen - complete, 100 micron	710101-000462
6	O-Ring (50 x 3)	770101-000039
7	Filter head 1"-Compact	710101-000452
8	Union seal (viton)	770102-000225
9	Connector 3/4"	700190-003316
10	Union nut	710101-000986
12	Nipple for 16mm pipe incl. seal	700190-003314

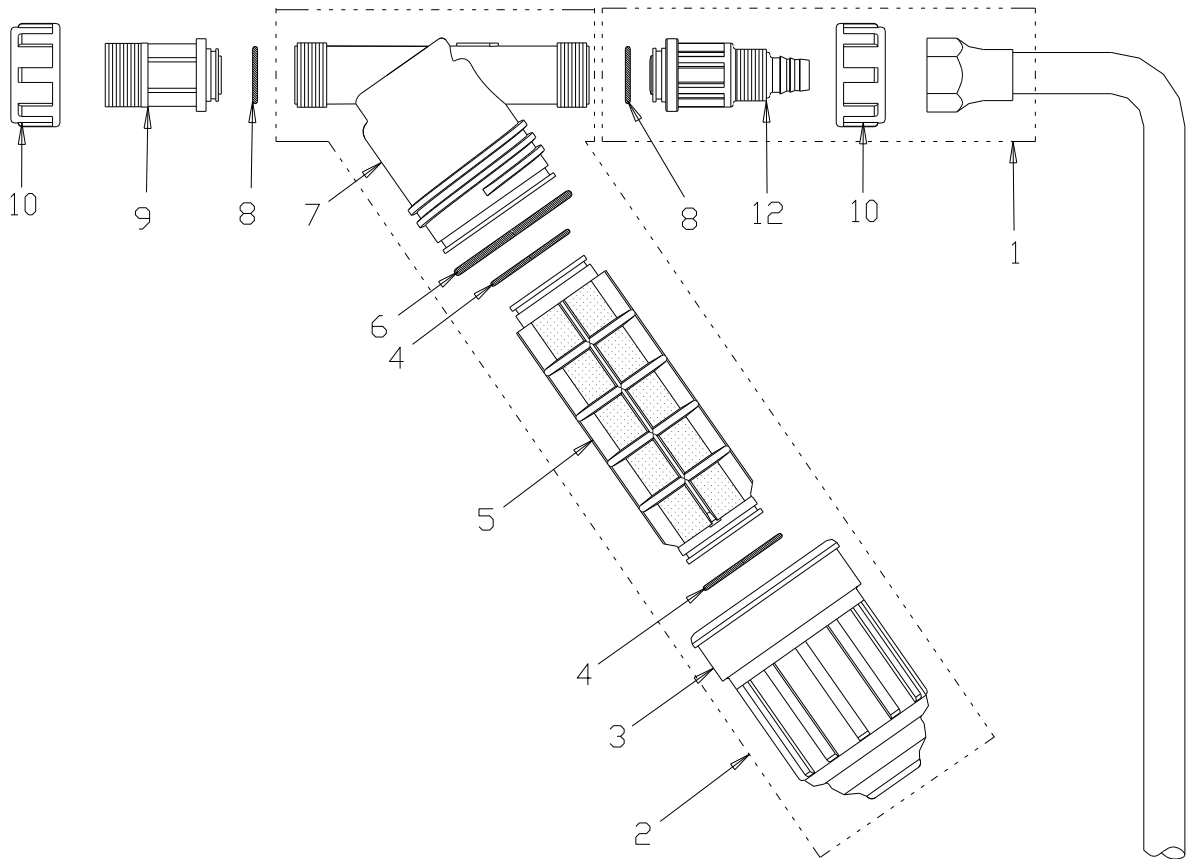

## CHEMICAL INJECTION PIPE

Ref.	Description	Cat. No.
	Injection pipe for 4-02 (4m.)	<b>700190-003287</b>
	Injection pipe for 4-01 (2m.)	<b>700190-003289</b>
1	Pipe 3/8" (Transparent)	<b>790208-000005</b>
2	Coupler for 16mm pipe	<b>710101-000990</b>
3	Connector 16mm	<b>780101-000739</b>
4	Union Nut	<b>710101-000986</b>
5	Nipple-16mm (incl. seal - viton)	<b>700190-003287</b>

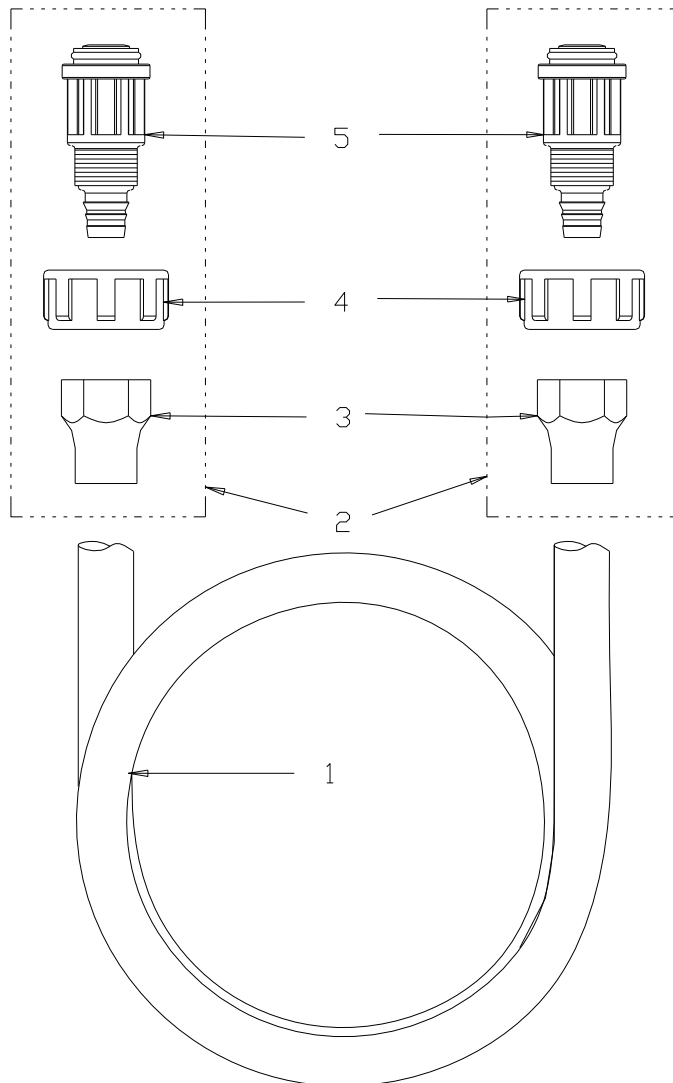

## UNIT ASSEMBLY

Ref.	Description	Cat. No.
1	Cylinder housing	700190-003258
2	Connector 1"-3/4"	710101-000985
3	Valve (incl. seal)	700190-003318
4	Valve seal (viton)	770103-000101
5	Union seal (viton)	770102-000225
6	Coupler for 16 mm pipe	700190-003255
7	Nipple-16 mm (incl. seal - viton)	700190-003314
8	Union nut	710101-000986
9	Cap 16mm	780101-000739
10	Coupler for 20mm pipe	700190-003256
11	Nipple - 20mm (incl. seal - viton)	700190-003315
12	Cap 20mm	780101-000738
13	Injection valve spring (0.7)	760107-000060
14	Injection valve housing assembly (black)	700190-003305
15	Injection valve housing assembly (blue)	700190-003306
18	Cap	710101-000977
19	Stainless steel sling	710103-004425
22	Stainless steel nut UNC 1/4"	700102-000366
23	Stainless steel bolt - 1/4" X 1/2"	760101-000423
24	Clamp - upper half	710101-000971
25	Clamp - lower half	710101-000972
26 or 27	Cut-out standard 3/4" NC hydraulic valve (cut-out)	700102-000366 700190-003248
28	Motor & pump assembly - complete	700190-003249
29	Cap seal	770102-000074
30	Cylinder body cap	710103-004196
31	Connector 25mm x 1"-female	780104-000498
32	Bearing disc	700190-003313
33	Motor seal large	710101-000962
34	Motor seal small	710101-000961
35	Pump seal seat	710101-000968
36	Pump seal (viton)	770104-000179
37	Pump seal (rubber)	770105-000001
38	Valve retaining ring	710101-000987
39	Union nut clip	710101-000974

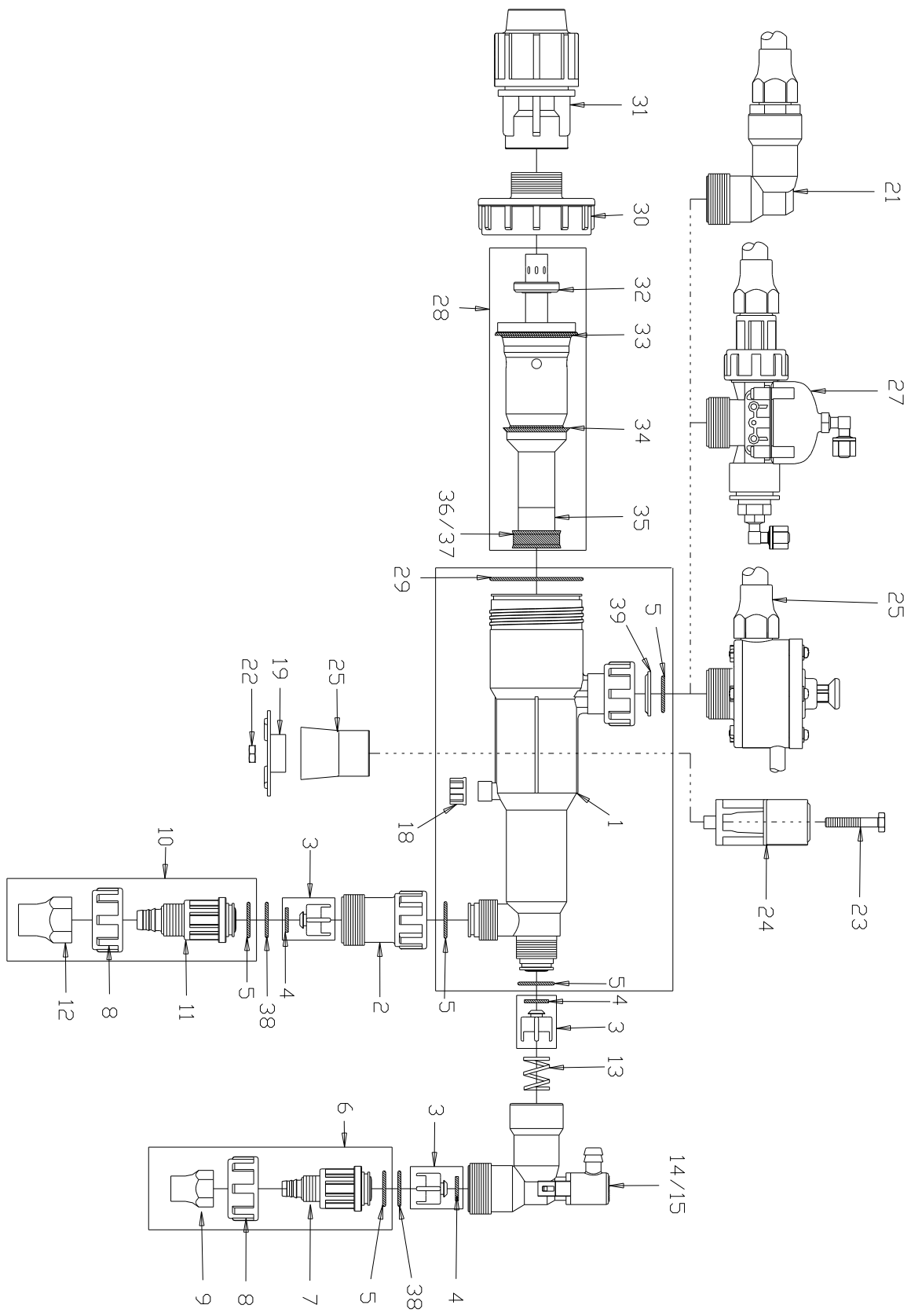



## UNIT ASSEMBLY – GRAVITY FEED TYPE 4-02

Ref.	Description	Cat. No.
1	Automatic air release Assembly	700190-003299
2	Anti-siphon valve	700190-003304
3	Pipe 3/8"-(4m) incl. fittings	790208-000005
4	Check valve and nipple 3/4"	700190-003310
5	Pipe 3/8"- (4m) incl. fittings	700190-003287
6	Pipe 1/2"- (2m) incl. fittings	700190-003293
7	1"C Filter, Blue, 30 mesh	010001-000051
8	Union nut	710101-000986
9	Connector 3/4"	700190-003316
10	Drive water pipe	700190-003294
11	Injection valve housing assembly (Blue)	700190-003306
12	1"C Filter, 155 mesh (Black)	011001-000001
13	Air release pipe 8/12 (transp.-60cm)	700190-003300
14	3/4" NC hydraulic valve (cut-out)	700190-003248

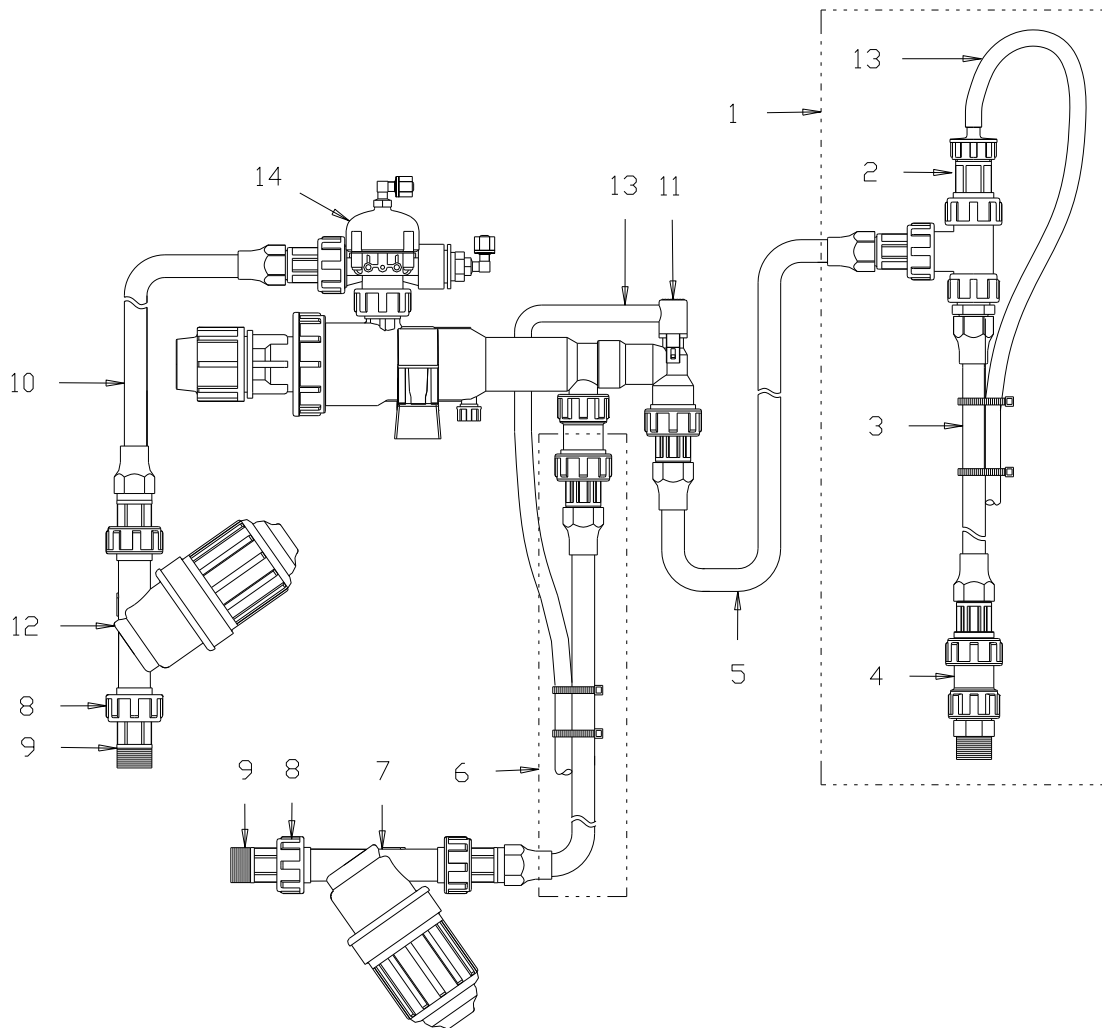

## AUTOMATIC AIR RELEASE ASSEMBLY (for 4-02)

Ref.	Description	Cat. No.
1	Pipe 3/8" (4m) including fitting	700190-003286
2	Anti siphon valve	700190-003304
3	Connector 1"-3/4"	710101-000985
4	3/4"-3/4" Nipple	780101-000965
5	Air release pipe 8/12 (transp.-60cm)	700190-003300
7	Toothed clamps	760108-000095

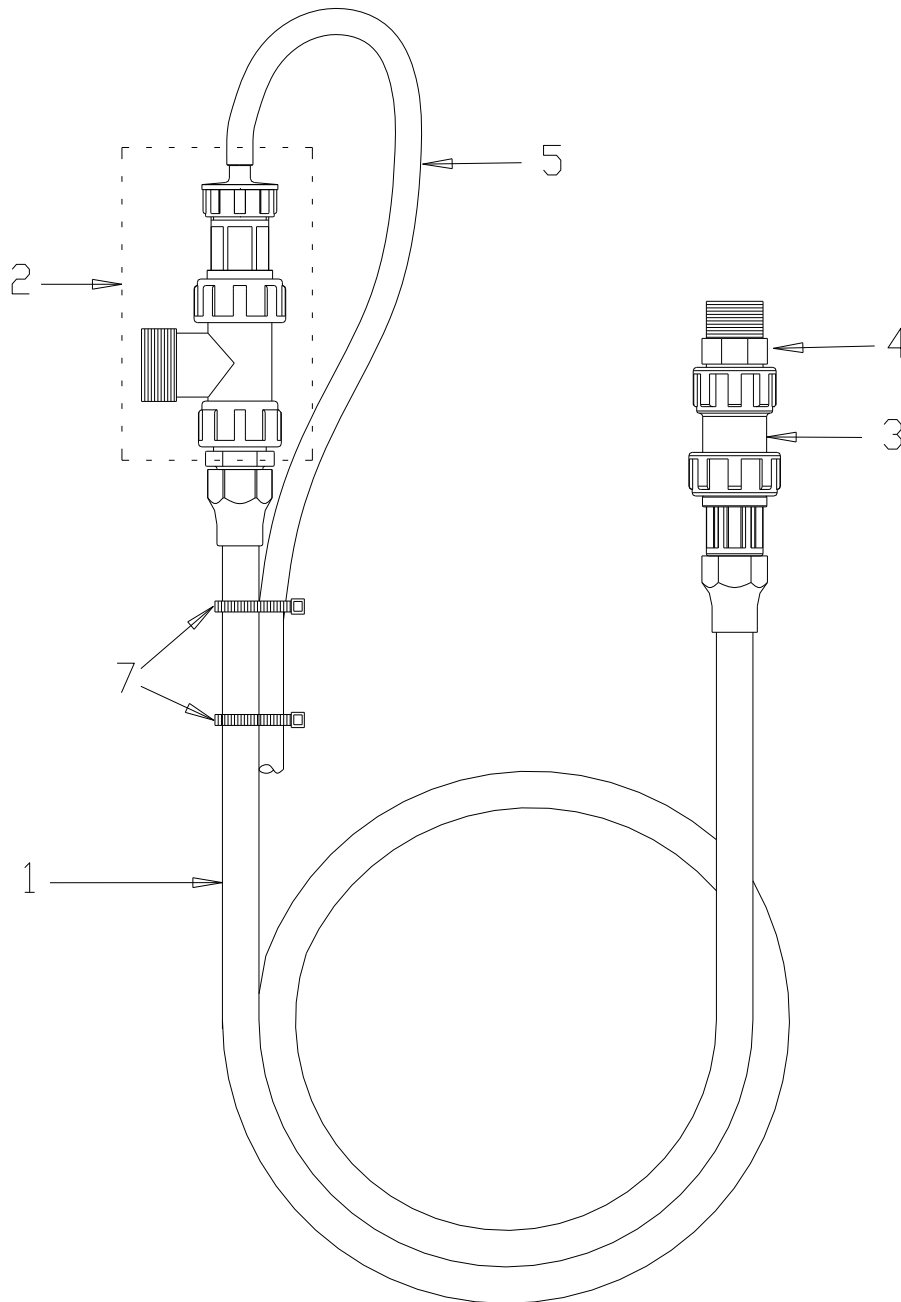

## FLOW REGULATOR ASSEMBLY WITH FILTER

Ref.	Description	Cat. No.
	<b>Flow regulator assembly (incl. 1 capsule)</b>	700190-003271
		700190-003272
		700190-003273
		700190-003274
		700190-003275
	<b>Flow regulator ass. (incl. 5 capsules)</b>	700190-003270
1	Flow regulator assembly filter	700190-003269
2	Flow reg. capsule 10 l/hr (incl. 0-ring)	700190-003263
3	Flow reg. capsule 20 l/hr (incl. 0-ring)	700190-003264
4	Flow reg. capsule 40 l/hr (incl. 0-ring)	700190-003265
5	Flow reg. capsule 60 l/hr (incl. 0-ring)	760108-000095
6	Flow reg. capsule 80 l/hr (incl. 0-ring)	700190-003267
7	Capsule 0-ring (viton)	770102-000224
8	Union seal (viton)	770102-000225
9	Connector 3/4"	700190-003316
10	Union nut	710101-000986
11	Blue filter head	700190-001168
12	O-Ring (Viton 50 x 3)	770102-000237
13	Seal (viton) - cylinder	770101-000068
14	Cylinder 120 mesh for blue filter	700101-000284
15	Blue filter housing	710101-000450
16	1"M-3/4"F Thread filter, Blue, 130 micron (120 mesh)	010001-000053

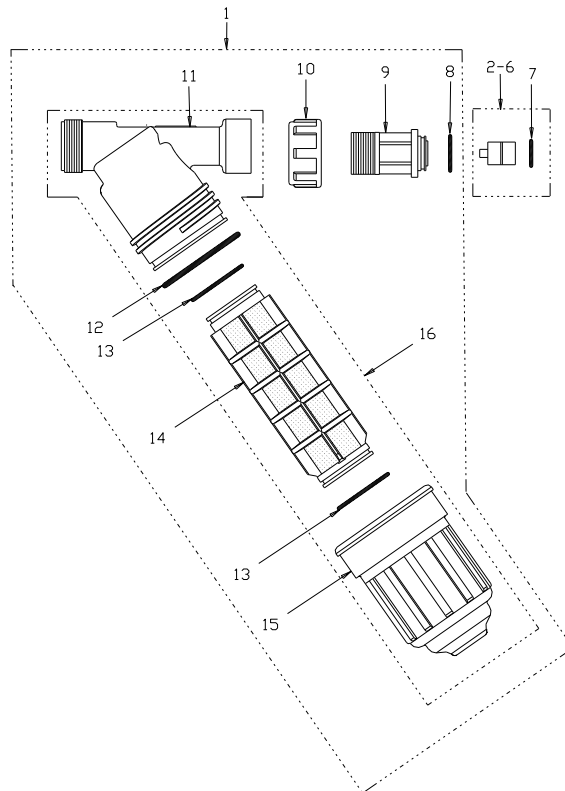

## ADDITIONAL ITEMS FOR FERTILIZER INJECTOR

Ref.	Description	Cat. No.
	Spare parts kit for fertilizer injector	<b>700190-003251</b>
	Set of seals for fertilizer injector	<b>700190-003252</b>
	Set of piston seals - viton	<b>700190-003253</b>
	Set of O-rings for fertilizer injector	<b>700190-003254</b>
	Motor & pump assembly - complete	<b>700190-003249</b>
	Instructions manual - English	<b>760108-000095</b>
	Instructions manual - Spanish	<b>910101-000316</b>

Contact us for support and orders, [click here >](#)