



D-070 M1 PN 16



Dynamic Combination Air Valve **PATENTED**

Description

The D-070 M1 Dynamic Combination Air Valve is a unique valve, operating without a float and utilizing the rolling diaphragm principle. This unique structure allows the dynamic air valve to discharge air from the water system in a controlled and gradual manner, thus preventing slam and local up-surges. When vacuum (down-surge) occurs, the valve reacts quickly to admit large volumes of air into the water system, thus impeding down-surges and, consequently, all pressure surges in the line. The air & vacuum component of the dynamic air valve is normally closed when the line is not operating, thus preventing the infiltration of debris and insects into the water system.

Applications

- Pumping stations, deep wells and distribution lines.
- Systems that are prone to slam and local and system surges.
- Sites that require a combination of means to reduce water hammer or surges.
- Sites that require an air valve with a low profile due to lack of space.

Operation

When the system is charged and the pipeline begins to fill with water, air flows in the pipeline and enters into the dynamic air valve, raising the rolling diaphragm sealing assembly to the open position. Air is then discharged, mainly through the lower chamber large orifice as well as small amounts of air released through the upper chamber operating valve orifice. When the ensuing water enters the dynamic air valve, it fills the lower chamber and some of it flows up through the orifice chamber and enters into the upper operating chamber, raising the float of the operating valve which pushes the sealing mechanism to its sealed position. Pressure develops inside the upper operating chamber, bringing about a controlled lowering and sealing of the rolling diaphragm sealing assembly, which, in turn, closes the lower chamber large orifice.

NOTE: It is recommended to attach a drainage pipe to the connection on the large orifice outlet as some water will be expelled from the orifice during this closure stage. The size of the drainage pipe should be, at a minimum, the diameter of the outlet and the unattached end should remain open to the atmosphere.

At this stage, only the automatic air release component continues to function and releases air through its small orifice. With a reduction in line pressure, during drainage or shut-off, the pressure in the valve is reduced and is lower than the outside atmospheric pressure. The vacuum created will cause the rolling diaphragm

sealing assembly to rise up into its open position, opening the lower chamber large orifice and allowing the intake of air from the atmosphere into the system.

Main Features

- Working pressure range: 0.2 - 16 bar.
- Testing pressure: 25 bar.
- Maximum working temperature: 60°C.
- Maximum intermittent temperature: 90°C.
- Internal components are corrosion-resistant.
- Prevents slam and reduces water surges in the air valve and the pipeline.
- Prevents the intrusion of debris and contaminants into the system.
- Valve is lightweight and small for easy installation; its operation simple and reliable.
- Built-in connection at the outlet for surplus water drainage.
- Smooth and gradual closing unaffected by water flow.
- Extremely quiet closing.
- Automatic air release component releases large quantities of air without becoming obstructed.

Valve Selection

- Sizes: 4", 6", 8" and 10".
- Valves are manufactured with flanged ends to meet any requested standard.
- Optional:
D-070 – sizes: 3"–8", 12"
D-070 P – Sizes: 2", 3" (threaded or flanged) & 4" (flanged only); made of composite materials with a working pressure: 0.2 - 10 bar.
- Valve coating: fusion bonded epoxy coating according to the standard DIN 30677-2.
- Other coatings are available upon request.
- Additional one-way D-070 M1-I valve - intakes air only, without allowing air discharge.

Note

For best suitability, it is recommended to send the fluid chemical properties along with the valve request. Upon ordering, please specify: model, size, working pressure, threads standard and type of liquid.

AIR & VACUUM FLOW RATE

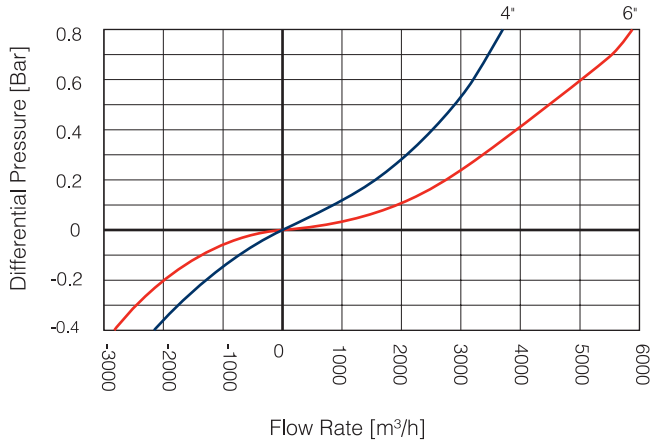

AUTOMATIC AIR RELEASE FLOW RATE

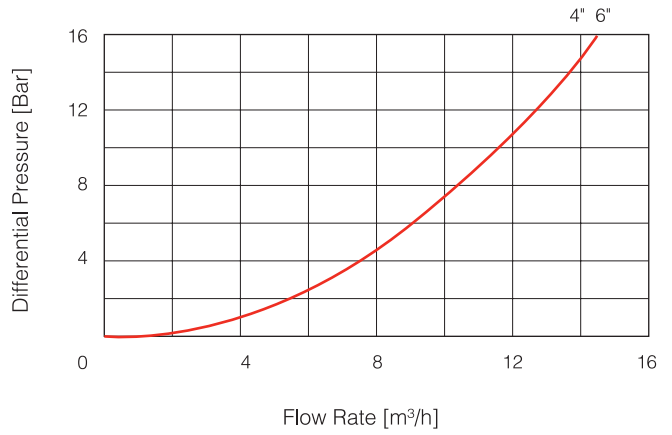

AIR & VACUUM FLOW RATE

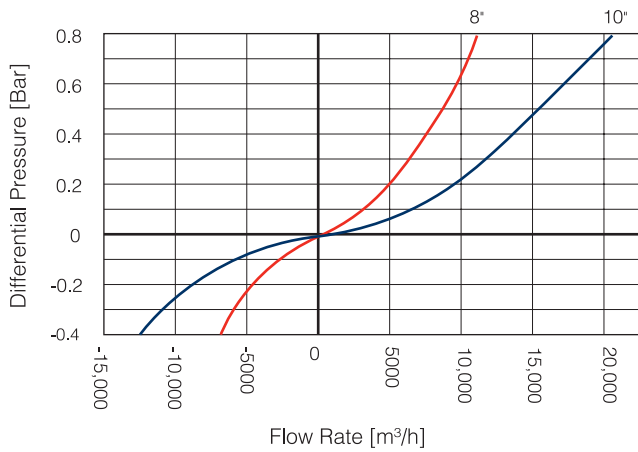

AUTOMATIC AIR RELEASE FLOW RATE

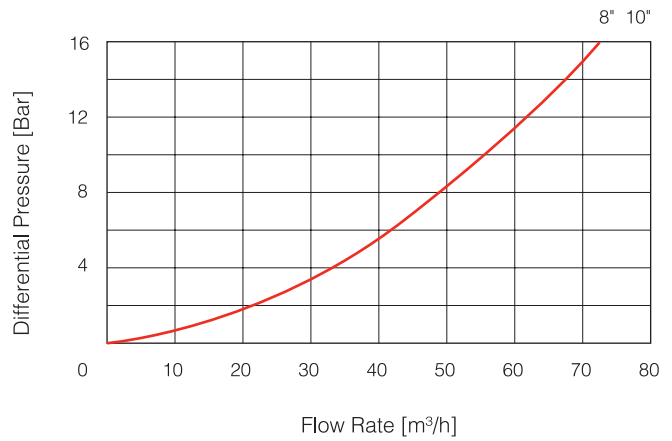

DIMENSIONS AND WEIGHTS

Nominal Size	Dimensions mm		Connections		Orifice Area mm ²	
	A	B	C	D	Auto.	A & V
4" (100 mm)	247	291	3" Vic / BSP / NPSM	3/8" BSP Female	7.8	5153
6" (150 mm)	285	311.5	4" Vic.	3/8" BSP Female	7.8	7850
8" (200 mm)	403	393	6" Vic.	1 1/2" BSP Female	12	17553
10" (250 mm)	437	455	8" Vic.	1 1/2" BSP Female	12	31400

PARTS LIST AND SPECIFICATION

No. Part	Material
1. Operating Valve Body	Reinforced Nylon
2. Discharge Outlet	Polypropylene
3. Rolling Seal 4" 6"	EPDM
Sealing Assembly 8" 10"	EPDM + Reinforced Nylon + Stainless Steel 316
4. Operating Assembly	Polypropylene + Stainless Steel 304
5. Clamping Stem	Reinforced Nylon
6. O-ring	BUNA-N
7. Bolt, Nut & Washer	Steel Zinc Cobalt Coated
8. Cover	Ductile Iron
9. Rolling Diaphragm Sealing Assy.	Reinforced Nylon + EPDM + Stainless Steel 304 + Natural Rubber + Fabric
10. Orifice Seat	Bronze
11. Body	Ductile Iron

D-070 M1 4", 6"

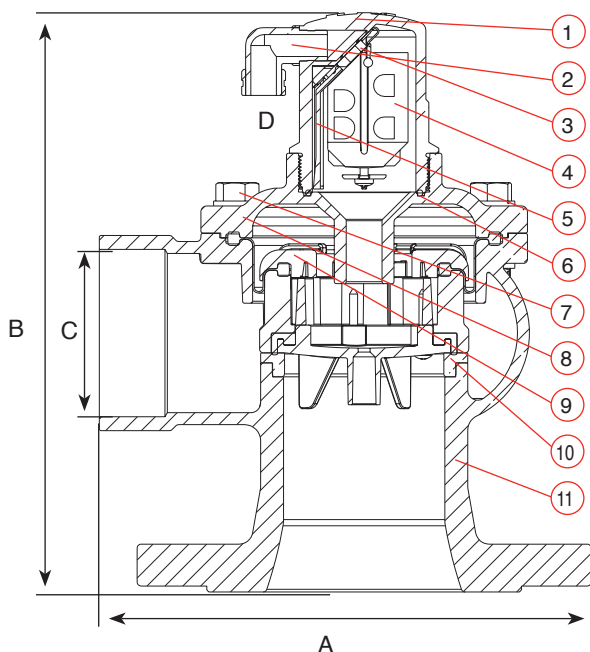

D-070 M1 8", 10"

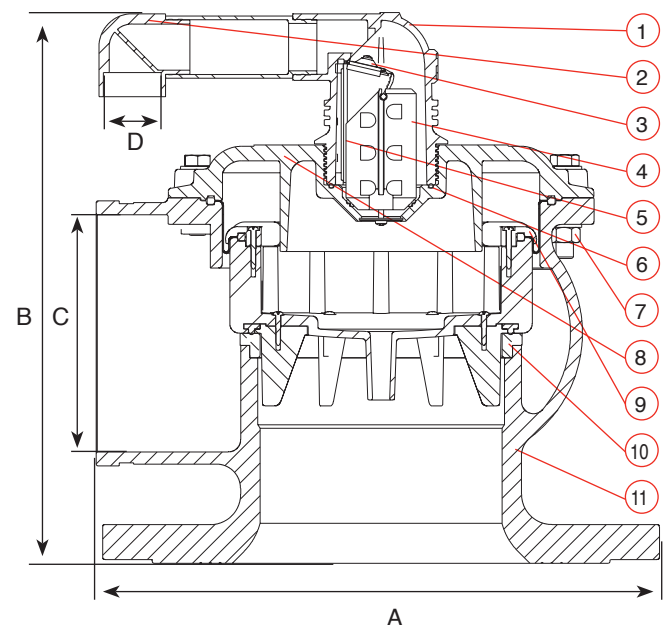

[Online Orders D70 dynamic air valves ari valves aqestia](#)