

R-20 Y

Level control Valve - Vertical Float



Introduction

Based on a unique technology that combines innovative design and performance, the Eliptix line of hydraulic control valves offers optimal system solutions. The Eliptix line are suitable for installation in the areas of waterworks, irrigation systems and landscape.

With an innovative elliptical structure, the Eliptix control valve line offers accurate, stable and excellent regulating capabilities for a wide range of flow rates.

Requiring exceptionally low operating pressure for valve opening and rapid, yet gradual closing.

The Eliptix valve is designed for minimal head loss and increased revenue.

With a simple mechanism and a minimal amount of moving parts, the Eliptix hydraulic control valve line delivers reliable operation, extended durability and minimize cavitation risk.

Cost reduction with fast and simple inline maintenance.

Rugged, high quality construction meets applicable engineering standards.

Description

The Eliptix Level control Valve - Vertical Float model R-20 Y is used to maintain a preset minimum and maximum water level in a reservoir or water tank. The valve is activated by line pressure according to a modulating bi-level float.

The valve will open when the water level of the reservoir reaches the lower preset level of the vertical float.

As the water level reaches the maximum preset level of the vertical float, the valve will gradually close by re-pressurizing the control chamber.

Product Features

- Rugged, high quality construction meets applicable engineering standards
- Long service life and low maintenance
- Unique technology, innovative design and performance
- Free and unobstructed liquid flow with minimal head loss
- Designed to reduce cavitation
- Elliptic diaphragm reacts faster with less movement
- Small control chamber enables quicker response

Schematic Control Loop Diagram

COMPONENTS

1. Y - Strainer
2. Ball Valve
3. Restriction Orifice
4. Vertical Float

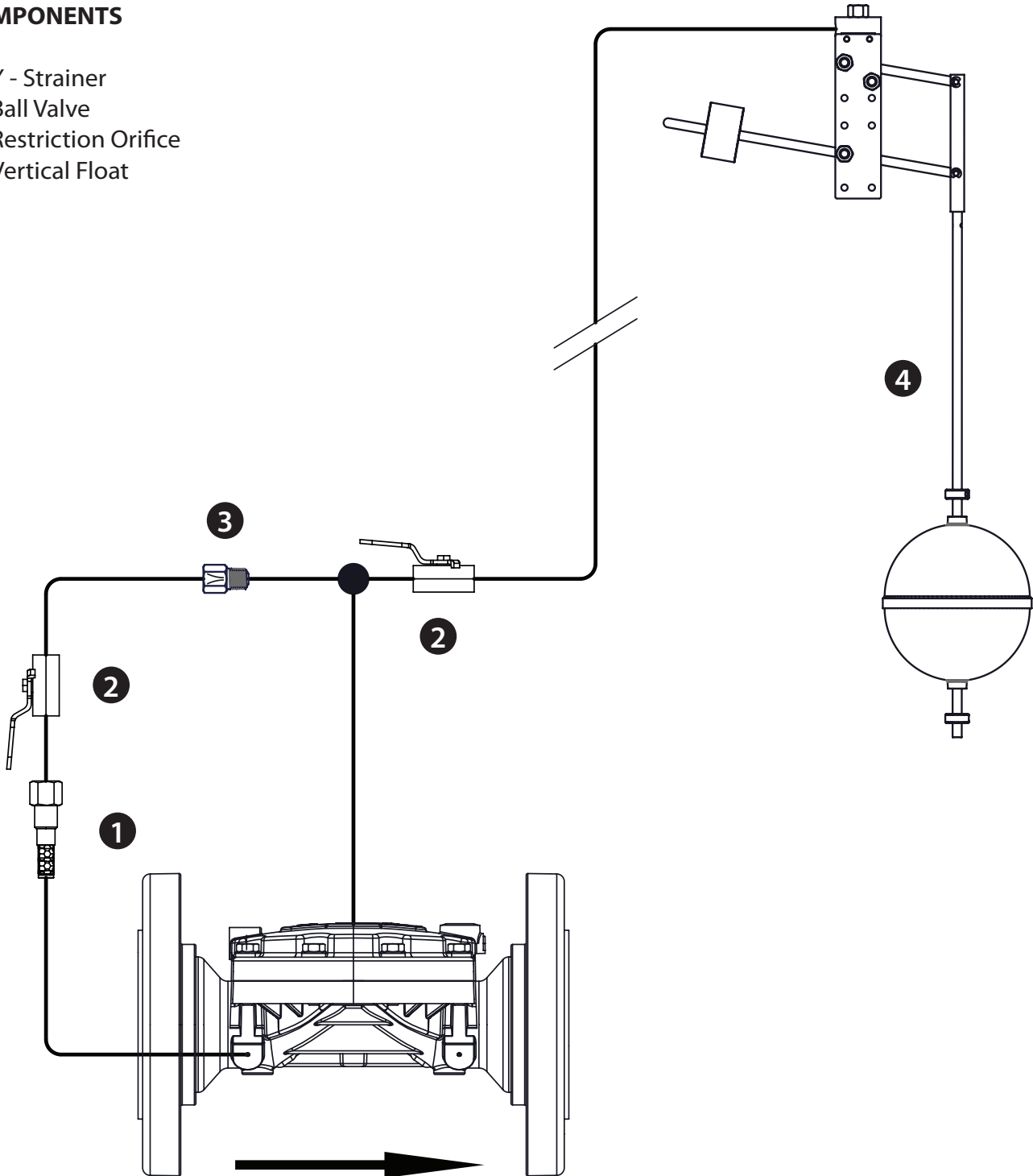

Level control Valve - Vertical Float

Purchase Specifications

The control valve shall be a hydraulically operated, pilot controlled, weir type, in-line serviceable valve. The main in-line hydraulic control valve shall have only two moving parts, the resilient diaphragm and the spring. The diaphragm shall be the only sealing component of the control valve.

Valve Technical Specifications*

Series R-20 PN10

Self-actuated, WEIR type diaphragm actuated, hydraulic control valve

*For dimensions and weights, please refer to the Eliptix Basic Valve leaflet

Material	Body & Bonnet	Composite Materials: Reinforced Nylon / Polypropylene
	Diaphragm	Natural Rubber / EPDM
	Bolts	Steel, Zinc Cobalt Coated / Stainless Steel SAE 316
	Piping & Tubing	Reinforced Nylon / Stainless Steel SAE 316
Pressure Rating	Maximum working pressure - 10 bar Minimum working pressure - 0.4 bar (depending on type of diaphragm)	
Water Temp. Range	5° to 60°C	

Installation and Storage Recommendations

- Always flush the pipeline to remove debris before the installation of the valve.
- Arrow on the valve bonnet must match the actual flow direction.
- Tighten bolts to the recommended torque for the specific size and model of the Eliptix valve.
- Do not over-torque.
- Tighten bolts using the crossover method.
- If the Eliptix valve is for use in ambient or fluid temperatures below freezing, consult your nearest A.R.I. distributor. If shut down during cold weather, the valve control space and the control system must be drained.

When ordering, please specify

- 1) Eliptix Control Valve Series R-20 model y
- 2) Eliptix valve size
- 3) Desired end connection / standard
- 4) Static inlet pressure (when valve is closed)
- 5) Dynamic pressures (min – max)
- 6) Flow rates (min-max)

R-20 Eliptix Level Control Valves Orders and spare parts Ari Valves