

AMIAD WATER SYSTEMS Ltd.

2" Compact Stand-Alone Spin Klin™ Filter Air Aided Flushing (A.A.F.)

Serial number:	_____
Order number:	_____
Catalog number:	_____
Filtration degree:	_____
Tested by:	_____

Installation and Operation Instructions

910101-000883 / 12.2020

Amiad Water Systems Ltd. 2" Compact Stand-Alone Spin Klin™ Filter Air Aided Flushing (A.A.F.)

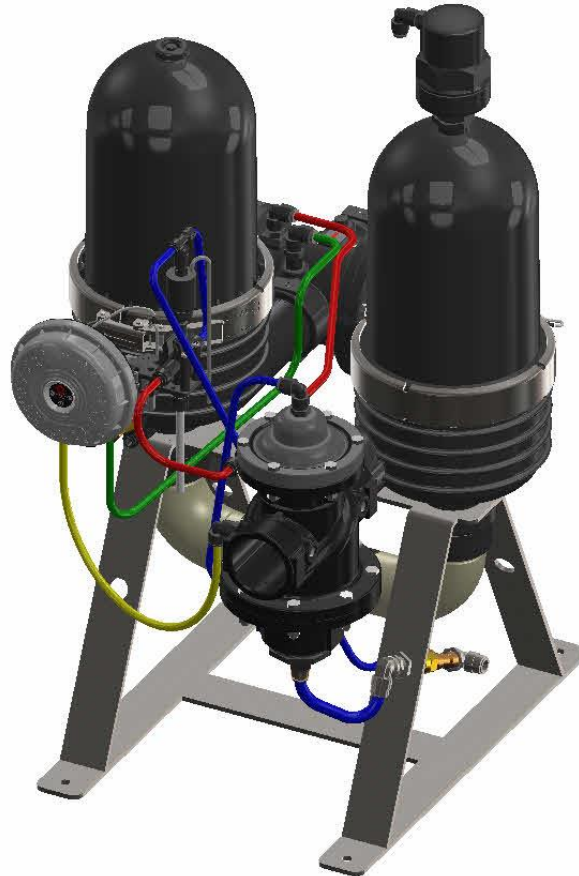

Disclaimer:

Copyright © 2020 Amiad Water Systems Ltd. All rights reserved.

The contents of this document, including without limitation all information and materials, images, illustrations, data, drawings, names and any other such materials that appear in this document are the sole property of Amiad Water Systems Ltd. ("Amiad"), including any intellectual property rights, whether registered or not, and all know-how contained or embodied therein (together the "Content"). Amiad may alter, remove or change the Content without any further notice. You may not reproduce, copy, modify, create derivative works from, sell or participate in any sale of, or exploit in any way, in whole or in part, any of this document or its Content.

The confidential nature of and/or privilege in the file enclosed is not waived or lost as a result of a mistake or error in this file. If you received this file in error, please notify Amiad immediately at info@amiad.com.

This document does not replace any certified drawing, procedure or information provided by Amiad in reference to a specific customer, site or project.

Amiad assumes that all users understand risks involved within this file and/or its attached materials. This document is given in good faith and is not intended to impose any obligation to Amiad. While every effort has been made to ensure the information in this manual is accurate and complete, we would appreciate if you can bring any errors or omissions to the knowledge of Amiad or consult Amiad experts or its authorized representatives if you have any questions.

Amiad Water Systems Ltd. D.N. Galil Elyon 1, 1233500, Israel Tel: 972 4 690 9500 | Fax: 972 4 814 1159 Email: info@amiad.com

Table of Contents

1. Introduction	4
2. Safety Instructions	4
3. System Drawing	7
4. Description & Operation.....	8
5. Technical Data	11
6. Installation and Operation.....	13
7. Spin Klin – System Maintenance	14
Seasonal Maintenance - Cleaning the Discs	15
8. Troubleshooting.....	18
9. Parts Schedule	19
9.1 Parts List.....	20
10. Valves - Parts Schedule and Parts List	21
10.1 Standard Valves Parts List.....	22
10.2 DW Valves Parts List	23
10.3 AW Valves Parts List	24
10.4 SW Valves Parts List.....	25
11. System Drawings (to be amended per each specific ordered)	26
12. Amiad Limited Warranty	27

With any inquiry please quote Filter Serial Number, located on the filter housing.

1. Introduction

General

Amiad Water Systems congratulates you on purchasing the 2" Spin Klin Compact Filter. All Amiad Filtration Systems are easy to install, use and service and do not require special skills to operate them.

For proper operation and maintenance of the filtration system please follow the instructions in this manual.

This Amiad 2" Spin Klin Compact filter is an automatic self-cleaning filter designed for non-hazardous liquids only and within the pressure and temperature framework described in the specifications table.

2. Safety Instructions

General Safety Instructions

- Amiad filtration products always operate as components in a larger system. It is essential for the system designers, installers and operators to comply with all the relevant safety standards.
- Prior to installation, operation, maintenance or any other type of action carried out on the filter, read carefully the safety, installation and operation instructions.
- During installation, operation or maintenance of the filter all conventional safety instructions should be observed in order to avoid danger to the workers, the public or to property in the vicinity.
- Please note: The filter enters into a flushing mode automatically, without prior warning.
- No change or modification to the equipment is permitted without a written notification given in advance by the manufacturer or by its representative, on the manufacturer's behalf.
- Always observe standard safety instructions and good engineering practices whilst working in the filter's vicinity.
- Use the filter only for its intended use as designed by Amiad, any misuse of the filter may lead to undesired damage and may affect your warranty coverage. Please consult with Amiad prior to any non-regular use of this equipment.

Installation

General

- Install the filter according to the detailed Installation Instructions provided with the filter by the manufacturer and according to the description given in this manual.
- Make sure to leave enough clearance so as to enable easy access for future treatments and safe maintenance operations.
- The user should arrange suitable lighting at the area of the filter to enable good visibility and safe maintenance.
- The user should arrange suitable platforms, ladders and safety barriers to enable easy and safe access to the filter without climbing on pipes and other equipment. The user should verify that any platform, barrier, ladder or other such equipment is built, installed and used in accordance with the relevant local authorized standards.
- Check and re-tighten all bolts during commissioning and after the first week of operation.
- Use only appropriate standard tools and equipment operated by qualified operators when installing, operating and maintaining the filter.
- When installation is required in hazardous environment sites, underground or high above ground, make sure that the site design and the auxiliary equipment are appropriate and that installation procedures are carried out in accordance with the relevant standards and regulations.
- Ensure walking areas about the installation are slip free when wet.
- It is recommended to stabilize the drain pipe that might vibrate during flushing mode.

Shipment and transporting

- Shipping and transporting the filter must be done in a safe and stable manner and in accordance with the relevant standards and regulations.
- For shipping, lifting and positioning the filter, use only approved lifting equipment and authorized employees and contractors.

Electricity

- Electric wiring should be performed by an authorized electrician only, using standardized and approved components.
- Install a **lockable** main power cut-off switch close to the control panel.
- If due to site constraints, the control panel is installed without a clear line-of sight of the filter, an additional **lockable** power disconnect cut-off switch should be installed near each filter unit.
- Installation of the filter should be performed so as to avoid direct water splashing on the electrical components or on the control panel.

Pneumatics

- Install a **lockable** main cut-off switch, **featured with a pressure release mechanism**, on the compressed air supply line close to the control panel.
- Install non return valve before the compressed air valve on the accumulator tank.
- If the control panel is installed far away and there is no eye contact with the filter, a **lockable** compressed air cut-off switch, **featured with a pressure release mechanism**, should be installed near each filter unit.
- The user should make sure that the compressed air supplied to the filter never exceeds the maximum designated pressure for this filter. An air-pressure reduction valve should be installed on the compressed air supply line upstream of the filter's pneumatic inlet port.

Hydraulics

- Extra safety devices should be installed on hot water applications to avoid skin burn danger.
- The user should install a manual Water Cut-off Valve next to the filter's inlet port.
- In cases where the downstream piping network downstream of the filter is pressurized an additional manual Water Cut-off Valve should be installed next to the filter outlet port.
- The user should make sure that the system includes a Pressure Release / Drainage Valve to enable release of residual pressure prior to any maintenance procedure performed on the filter.
- The user should make sure that the filter is never exposed to water pressure exceeding the maximum designated pressure for this filter, if needed a Pressure Reduction Valve should be installed upstream of the filter's water inlet port.
- Please note that the maximum working pressure indicated at the filter's specifications table includes the pressure caused by fluid hammer and pressure surge effects.

Civil Engineering

- Make sure that the filter installation is done by Amiad qualified technicians.
- Make sure that any civil engineering work at the installation site such as construction, lifting, welding, etc. is done by qualified workers / technicians / contractors and in accordance with the relevant local standards.
- While using lifting equipment, make sure that the filter or the lifted part is chained securely and in a safe manner.
- Do not leave lifted equipment if there is no necessity. Avoid working below lifted equipment.
- Wear a safety helmet while using lifting equipment.
- Make sure that the flooring is sloped for drainage and to avoid accumulation of liquids.

Commissioning

- Read carefully the Commissioning and the First Start-up Operation instructions prior to any attempt to operate the filter.
- In order to achieve maximum performance and smooth operation of the filter it is crucial to perform the Startup and First Operation procedures exactly as described in this manual.
- Commissioning the filter should be done by an authorized Amiad technician, do not attempt to commission the filter unaccompanied since this may lead to undesired damage and may affect your warranty coverage.

Operation and Control

- Do not operate the filter before reading carefully and being familiar with its operation instructions.
- Observe the safety stickers on the filter and never perform any operation contradicting the instructions given.
- Never operate or use the filter for purposes other than its original design and operational envelope.

Maintenance

Before any maintenance or non-regular operation please read the following:

- Servicing the filter should be done only by technicians authorized by Amiad.
- Disconnect the filter from the power supply and lock the Main Power Switch.
- Disconnect the compressed air supply, release the residual pressure and lock the Pneumatics Main Valve.
- Disconnect the filter from the water system by closing and securing the Manual Inlet Valve. In cases where the downstream piping network is pressurized, close and secure the Manual Outlet Valve also.
- Release the residual water pressure by opening the Pressure Release / Drainage Valve.
- Empty the filter by opening the Drainage Valve.
- In hot water systems wait till the filter components cool off to a safe temperature.
- Place warning signs around the work area as required by the local standards and procedures.
- Inspect the filter's safety stickers and replace any damaged or faded sticker.

Mechanical

- When working on the filter use only appropriate standard tools.
- Always open and close valves slowly and gradually.
- Remove grease and fat material residues in order to avoid slipping.
- Before disconnecting the filter from the water supply, electricity and pneumatics and before releasing the filter's residual pressure do NOT:
 - loosen or unscrew bolts
 - remove any protection cover
 - open any service port flange
- Avoid splashing and water leakage so as to minimize slippage, electrification or damage to the equipment, caused by moisture.
- While using lifting equipment, make sure that the filter or the lifted part is chained securely and in a safe manner.
- Do not leave lifted equipment if there is no necessity. Avoid working below lifted equipment.
- Wear a safety helmet, goggles, gloves, and any other personal safety equipment required by the local standards and regulations.
- Human entry into a filter must be done in accordance with the relevant local safety instructions, standards and regulations for working in hazardous environment.
- Manual cleaning of filter media using high water pressure or steam should be performed in accordance with the cleaning system instructions, the local standards and regulations and without endangering the operator or the vicinity.
- Manual cleaning of filter element using acid or other chemical agents should be performed in accordance with the relevant material safety instructions, the local standards and regulations and without endangering the operator or his vicinity.

Before returning to regular operation

- Re-assemble any protection covers or protection mechanisms removed during service or maintenance operations.
- Make sure that all the tools, ladders, lifting devices, etc. used during the maintenance procedures are taken away from the filter area and stored
- In order to return the filter to regular operation, follow the First Start-up Operation instructions as detailed in your user manual.
- For filters used in potable water systems it is required to disinfect the filter according to the local water authority standards and regulations before putting it back to service.

Special Note

Before opening the filter clamp, make sure that there is no system pressure in the filter and in the accumulator tank.

3. System Drawing

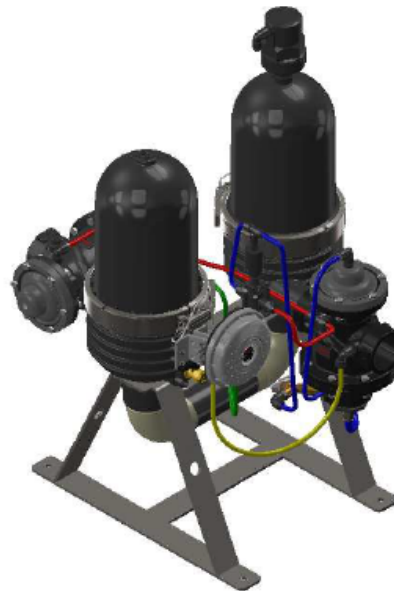
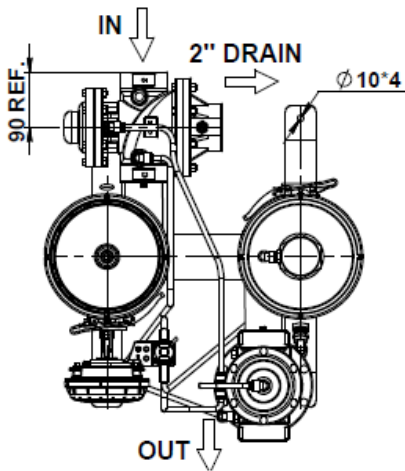
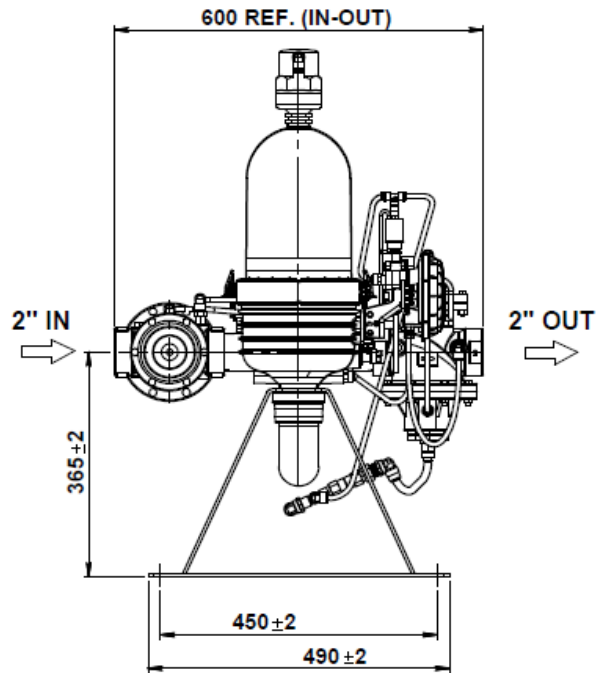
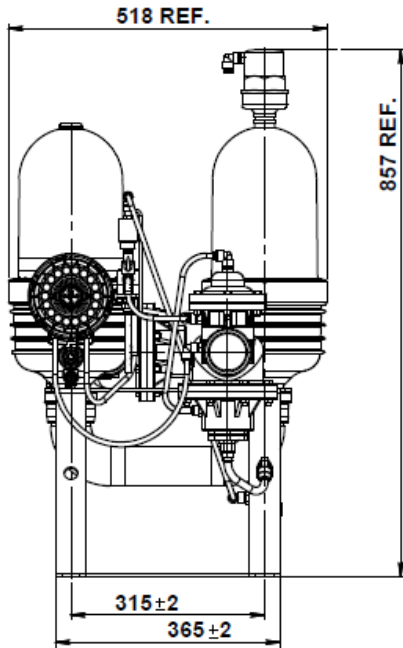

4. Description & Operation

Disc Filtration Technology

Amiad Water Systems uses a specially designed disc filtration technology. Thin, color-coded polypropylene discs are diagonally grooved on both sides to a specific micron size. A series of these discs are then stacked and compressed on a specially designed spine. When stacked, the groove on top runs opposite to the groove below, creating a filtration element with a statistically significant series of ridges and valleys, which trap the solids. The stack is enclosed in a corrosion proof and pressure resistant housing.

During the filtration process, the filtration discs are tightly compressed together by the spring's power and the differential pressure, thus providing high filtration efficiency. Filtration occurs while water is percolates from the outer diameter to the inner diameter of the element. Depending on the micron rating, there are from 18 (in 400 micron discs) to 32 (in 20 micron discs) stopping points in each track, thus creating the unique in-depth filtration.

Table of Filtration Grades of the Discs and Color Code

Color Code	Light Blue	Gray	Purple	Green	Brown	Black	Red	Yellow	Blue
Micron	10	20	40	55	70	100	130	200	400
PP / PA (Nylon)	PP	PP, PA	PP, PA	PP, PA	PP, PA	PP, PA	PP, PA	PP, PA	PP

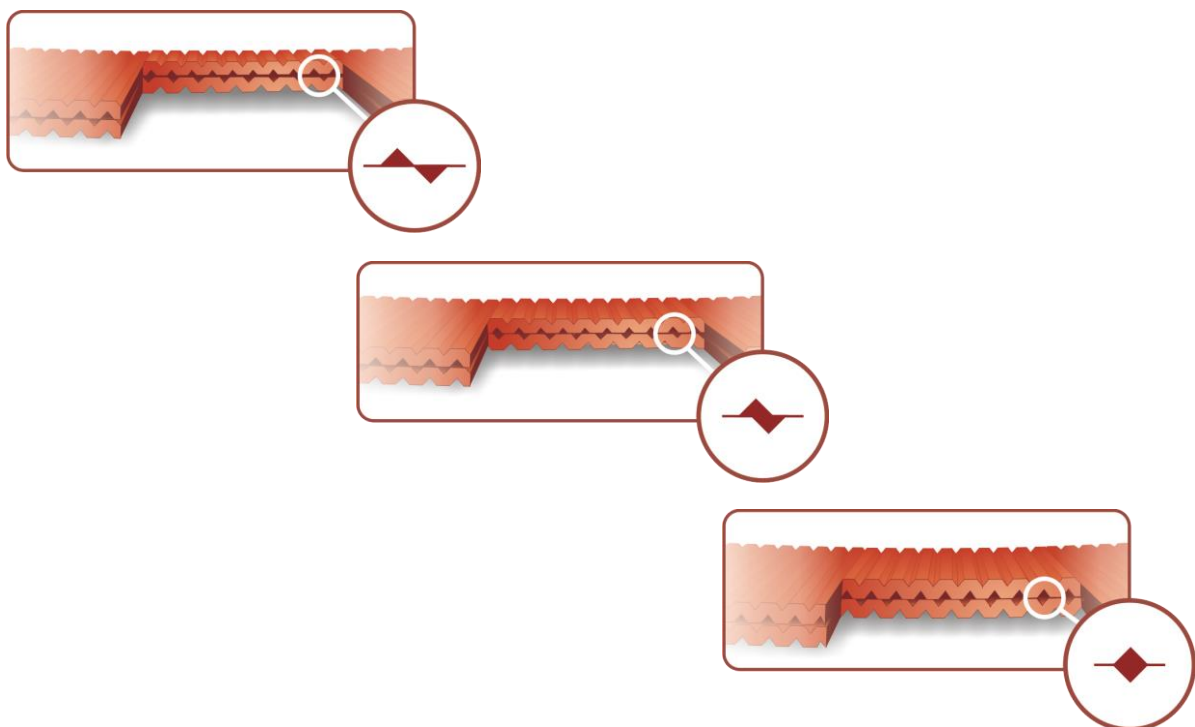

Spin Klin™ Technology

Spin Klin Spine – The Core of the Spin Klin Filtration System

The Spin Klin® discs are stacked on the Spin Klin® spine. The discs are color-coded according to micron size, and are assembled to suit your water filtration requirements. The spine assembly has a spring compression unit and an internal piston, which operate during alternate filtration or Back-flush modes. The spine assembly is specially designed to compress the discs tightly during the filtration process, forcing the water to flow between the grooves and trap the solids.

Spin Klin™ Automatic Back-flush Operation

Activated by a predefined command (differential pressure or time) each successive unit of the Spin Klin® system goes into the Back-flush mode. The inlet valve is shut as the drain is automatically opened. During the Back-flush process, the compression spring is released and the pressure difference is eliminated. The spine piston rises up, releasing the pressure on the discs. Tangential jets of clean water are pumped at high pressure in the opposite direction through nozzles at the center of the spine. The discs spin free and clear, loosening the trapped solids. Solids are quickly and efficiently flushed out through the drain.



Mode of Operation

Air Aided Flushing Spin Klin® Compact - A. A. F.

Operation and Maintenance Manual

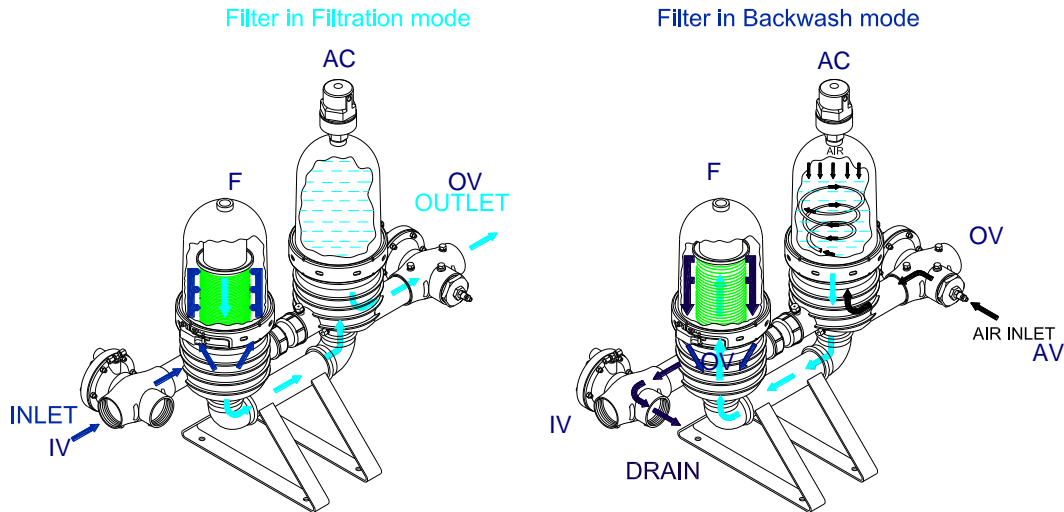

F	2" Spin Klin filter
IV	2"x2" Inlet valve
OV	2"x2" Outlet valve
AV	Air inlet
AC	Water accumulator

Filtration Process

- During the filtration mode water flows through the **INLET VALVE (IV)** to the 2" **SPIN KLIN FILTER (F)** and flows out clean through the **ACCUMULATOR (AC)** to the **OUTLET VALVE (OV)** to the customer.
- At this stage the **ACCUMULATOR (AC)** fills up with filtered water.

Back-flushing Process

1. The **CONTROLLER** transmits a pulse (as per pressure differential or time, whichever is first).
 2. Pneumatic command from the solenoid sends a pressure pulse to two users simultaneously.
 - A.** To the **INLET VALVE (IV)** converting it from filtration mode to Back-flush mode.
 - B.** To the **OUTLET VALVE (OV)**. Opens the **AIR PORT (AV)**.
- The compressed air enters the **ACCUMULATOR (AC)**.
 - The piston of the **SPIN KLIN FILTER (F)** rises, thus decompressing discs.
 - The air is mixed with filtered water and is carried to the **FILTER (F)** which is then Back-flush.
 - The ratio between air and water will rise until there is hardly any water at termination (air alone does not spin the discs).

5. Technical Data

Minimum water pressure:	0.8 bar (12 P. S. I.)
Maximum water pressure:	10 bar (145 P. S. I.) - 25° t (Depending on the filter material RPP or RPA)
pH:	4-11
Maximum temperature:	60°C (140°F)
Water flush volume:	12 liters (3.2 gallons)
Air pressure control:	Back-flushing pressure need to be minimum 6 bar (85 P.S.I) to maximum 8 bar (115 P.S.I)
Recommended air compressor:	¾" H. P. + 80 liter (21 gallons) tank
Air feed tube	not less than 1/2"

* Maximum operating pressure and temperature are interdependent parameters and are given for general reference only. Please consult your authorized Amiad representative for the application specific parameter

Air Volume and Flow Rate at Different Pressures

Air Pressure...6-8 Bar (85-115 PSI)						
Water Pressure		Time Seconds	Air Flow Rate		Total Volume	
Bar	PSI		Ft ³ /MIN	Liter/Minute	Liter	Ft ³
6	84	7	9.5	269	33.6	1.18
3.5	50	7	9.5	269	38.1	1.3
1.5	20	7	11	311.5	45.7	1.6

Recommended Setup Time

Flushing time	6-8 sec
Between flushing	1-2 hour
ΔP	5 m (7 PSI)

2" AAF Compact Control P&ID

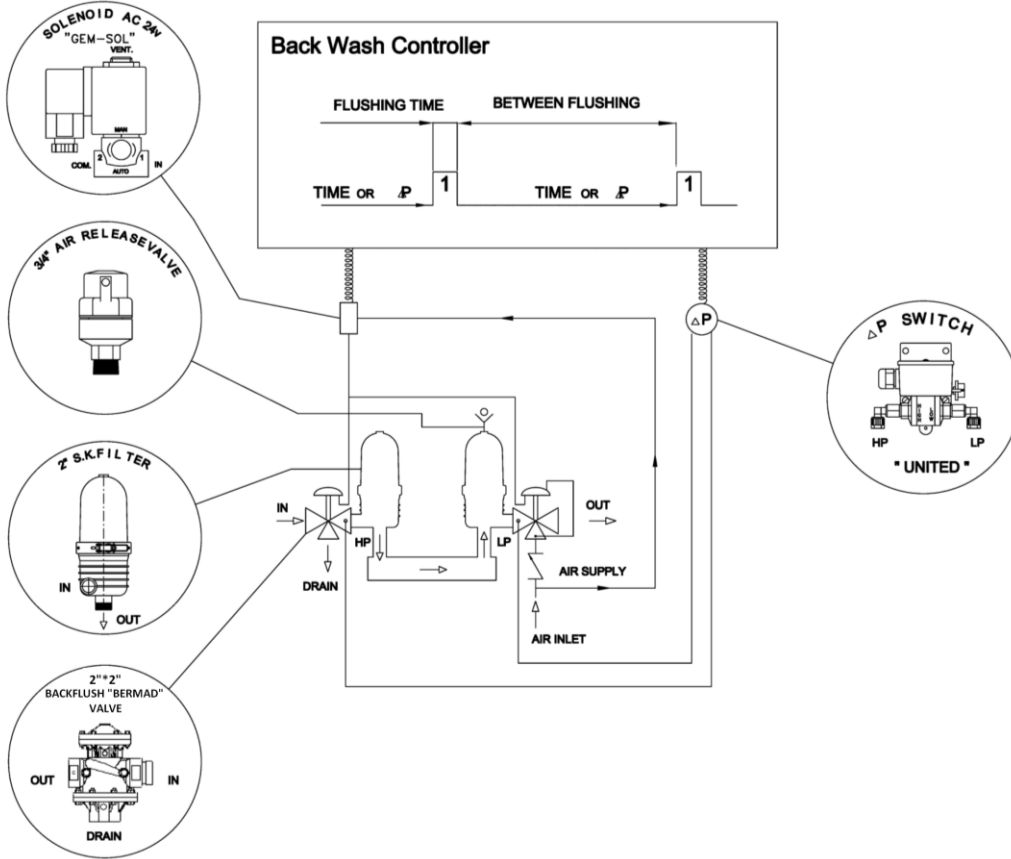

Headloss Chart

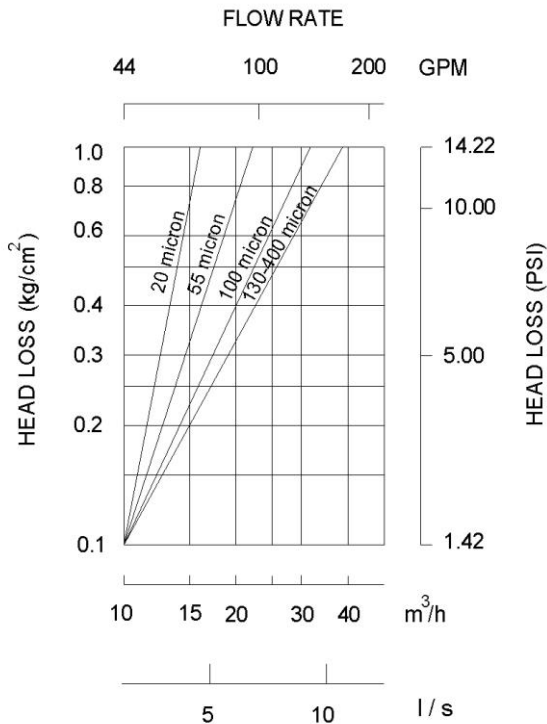

6. Installation and Operation

Installation

1. Remove from package, check contents.
2. Ensure correct orientation of INLET & OUTLET.
3. Connect the BACK-FLUSH pipe to the Drain port.
4. Check that the filter cover is closed correctly.
5. Connect air supply to the filter and the solenoid, minimum tube size 12 mm (1/2 ")

Controller

1. Refer to manufacturer's handbook before installing controller.
2. Check that the power is suitable for the solenoids & controller.
3. Make sure the solenoid manual switch is set to automatic.
4. Check that the pressure differential gauge is connected to the appropriate outlets – the high pressure & low-pressure pipes (High pressure is to the center of differential pressure meter).
5. Set the starting **point on the ADI-P to 5m (7 psi) above the filtration level.**

Initial Operation

1. Gradually open the inlet valve (make sure that the outlet valve, if installed, is open).
WARNING Take precaution while operating the filter as the filter may enter the Back-flush mode automatically, without prior warning.
2. Check the filter assembly and its connections for leaks.
3. Perform a Back-flush cycle by disconnecting the low-pressure tube from the differential pressure indicator (closing of the electrical circuit) – re-connect it immediately as Back-flush starts.
4. Verify that the hydraulic Back-flush valve closes after 20 seconds.
5. Verify that the hydraulic piston fully extends during Back-flush.
6. When the filter is clean, verify that the differential pressure between inlet and outlet does not exceed 3 m (5 PSI).
7. Check that the differential pressure indicator is set to 5m (7 psi)
8. Perform an additional Back-flush cycle manually by rotating the operation handle (turn clockwise 90°) located on the solenoid valve.

7. Spin Klin – System Maintenance

Monthly Maintenance

Check inlet / outlet pressures:

When the pressure differential is above 5 m / 7 PSI, activate automatic back flush of the Spin Klin filter. In the event that the pressure differential remains high, check for possible failures.

Check for leakages from the drain manifold:

When there is a leakage of water during the filtration stage, check for possible failure at the back-flush valve seals.

Back-flush controller performance:

Check that the controller timing parameters are correctly adjusted and activate automatic back-flush cycle. In the event of possible failure at the back-flush controller, check for possible failures.

Winterization:

In order to prevent the filter battery becoming damaged during water freezing – drain all the water from the filter battery and the command filter and leave the drain valve open.

To avoid damage or breakage, the filter, solenoid and command tubes, must be drained prior to frost periods. A step by step instructions:

1. Initiate a manual flush to make sure that the disc element will be clean for the shutoff period.
2. Close the isolation valves (inlet and outlet if exist).
3. Initiate an additional manual flush to release the pressure inside the filter.
4. If available, open any drainage filter body valve
5. Disconnect the tubes that supply water to the solenoid and to the controller sensors.

NOTE

Before performing any maintenance work on the battery, make sure all water and air connections are disconnected and that the pressure has been released.

Seasonal Maintenance - Cleaning the Discs

When manual cleaning of the discs is required, please follow the steps described below:

Make sure that system is not under pressure! Release the clamp and remove the cover. (Figure 1)
 Unscrew the butterfly-nut on the filtration element. (Figure 2)
 Remove the tightening cylinder. (Figure 3)

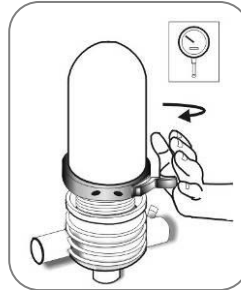

Figure 1

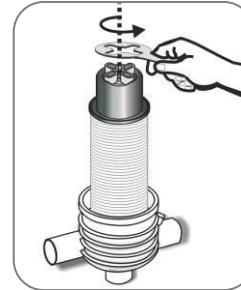

Figure 2

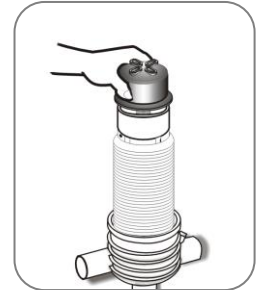

Figure 3

Remove the discs (for convenience we recommend using a plastic bag). (Figure 4, 5)

Tie each disc set on a string and place them in a cleaning solution (HCL, Chlorine, or other) refer to **“Cleaning Recommendations for Clogged Filtration Discs”**.

Thoroughly wash the discs with fresh water and then reassemble the discs on the spines. (Figure 6)

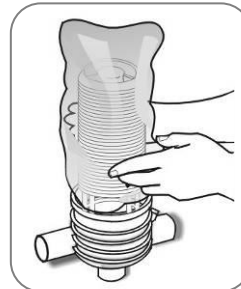

Figure 4

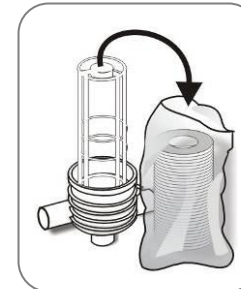

Figure 5

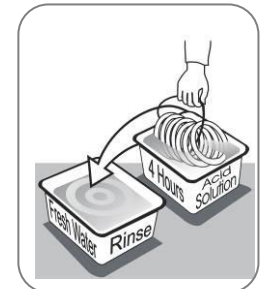

Figure 6

Check that the correct quantity of discs is assembled on the spine: when the discs are pressed with two hands, the top disc should be level with the imprinted circle on the outside of the spine. (Figure 7)
 Replace on the tightening cylinder and tighten the butterfly-nut, (Figure 8,9)

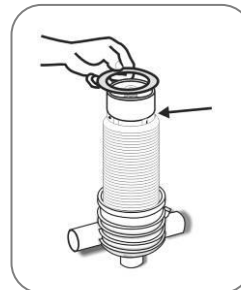

Figure 7

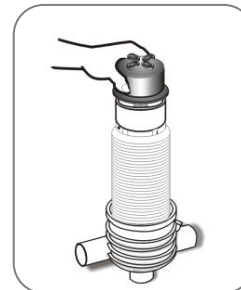

Figure 8

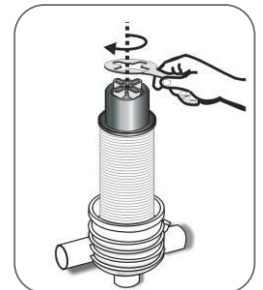

Figure 9

Reassemble the filter cover and tighten the clamp. (Figure 10, 11)

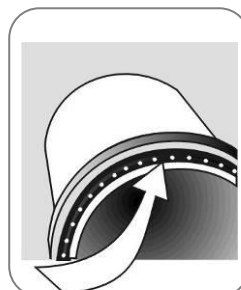

Figure 10

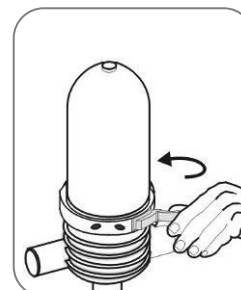

Figure 11

Cleaning Recommendations for Clogged Filtration Discs

Water-formed deposits may cause clogging of the filter discs. The formation of these deposits depends on the quality of the filtered water and environmental conditions like temperature, pH, light, duration of filtration and more.

Common water-formed deposits are:

- Biological or organic deposits (mostly mucous or oily to the touch, beige, brown or green in color)
- Iron oxide (rust) or other metal oxides
- Carbonates (white or gray deposit)
- Combinations of the above

If these deposits cannot be eliminated by pretreatment of the water, we recommend the following cleaning procedure:

Material and Equipment

- A well ventilated working place.
- 2 small containers (1 liter), 2 large containers (15 liter) and a stirring stick, all resistant to chemicals, preferably of polypropylene.
- Plastic rope to tie up the disc.
- Sodium Hypochlorite NaOCl - Strong oxidizing liquid, commercial concentration: 10%. Oxidizes and removes organic and biological deposits.
- Hydrochloric Acid HCl - Very corrosive liquid, commercial concentration: 30%. Dissolves and removes carbonates, iron oxide, and other deposits.
- Safety equipment: safety glasses, gloves, long pants, long sleeved shirt and shoes.

ATTENTION!

While working with chemicals protect yourself with the necessary safety equipment:

- Safety glasses, gloves, protective clothing
- Work in a well ventilated area
- Follow the manufacturer's instructions

Cleaning Organic and Biological Deposits

- Open the filter and remove dirty discs. **Attention** – Never open the filter before the pressure has been released.
- Arrange the discs loosely on the plastic rope
- Prepare a 5% Sodium Hypochlorite solution:
 1. Pour 5 liters of water into one of the large containers.
 2. Add 5 liters of Sodium Hypochlorite (10%) into the water.
- Soak the discs in the solution so that both sides are covered. To achieve maximum cleaning, agitate the discs several times with a stirring stick.
- Contact time with cleaning solution: up to 8 hours
- Remove the discs carefully from the solution, put them in the second large container and rinse them very well with clean water before placing them back in the filter.
- We recommend flushing the cleaned discs again in the filter to ensure that all chemical residues are removed.

The cleaning solution can be used for several sets of discs. As the cleaning activity of the solution deteriorates, it may be necessary to soak the discs for a longer time.

Cleaning Carbonates and Iron Deposits

- Open the filter and remove the dirty discs.
 - Arrange the discs loosely on the plastic rope.
 - Prepare a 5% Solution of Hydrochloric Acid:
 1. Pour 10 liters of water into one of the large containers.
 2. Carefully add 2 liters of Hydrochloric Acid (30%) into the water. Soak the discs in the solution so that both sides will be covered.
- PLEASE NOTE: Carbonates react violently with hydrochloric acid (foaming, gas evolution).** To achieve maximum cleaning, agitate the discs several times with a stirring stick.
- Contact time with cleaning solution: 1 - 8 hours.
 - Remove the discs carefully from the solution and rinse them well with clean water before placing them back in the filter.
 - We recommend flushing the cleaned discs again in the filter to ensure that all chemical residues are removed.

The cleaning solution can be used for several sets of discs. It may be necessary to soak the discs for a longer period of time as the cleaning activity of the solution deteriorates.

Cleaning Complex Deposits

If the composition of the deposit is not known, perform the following test:

- Take 5 discs for the test.
- Soak 2 discs in a 5% Sodium Hypochlorite Solution.
Preparation of the solution:
Pour 1 cup of water into a small container, then add 1 cup of Sodium Hypochlorite (10% NaOCl).
- Soak 2 discs in a 5% Hydrochloric Acid Solution.
Preparation of the solution:
Pour 2½ cups (= 500ml) of water into a small container, then add carefully ½ cup (= 100ml) of Hydrochloric Acid (30% HCl).
- Keep one disc as a control.
Observe the cleaning process:
If one of the solutions removes all of the deposit, clean the discs in that solution according to the instructions above.
If neither solution removes the deposit completely, continue with the test procedure.
- Remove the discs from both solutions, rinse them well with water and soak them in the second solution: put the two discs, which have been in the Sodium Hypochlorite Solution, in the Hydrochloric Acid Solution, and the other way around.
- Check the cleaning process:
If one of the treatments removes all of the deposit, clean all of the discs following the same two-step procedure in the exact same order. Rinse the discs well between the two cleaning processes. If the deposit hasn't been completely removed, send a set of untreated discs to the laboratory for further examination.

8. Troubleshooting

No Backwash Operation

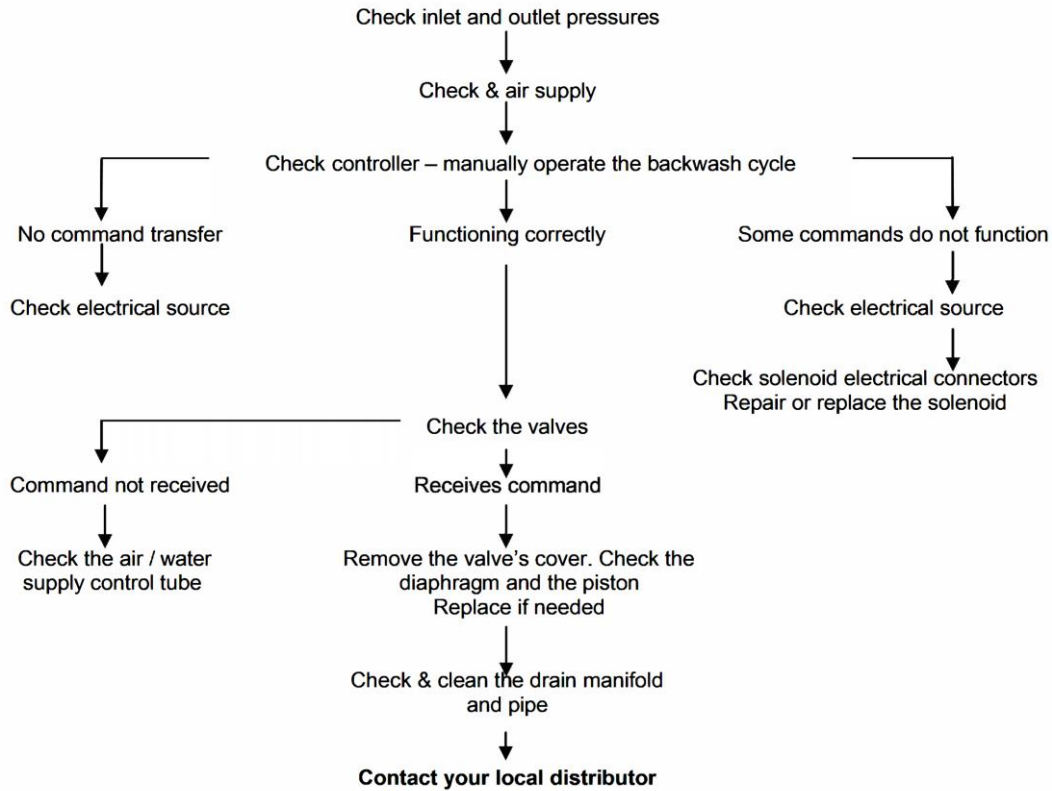

Continuous or Non-stop Backwashing

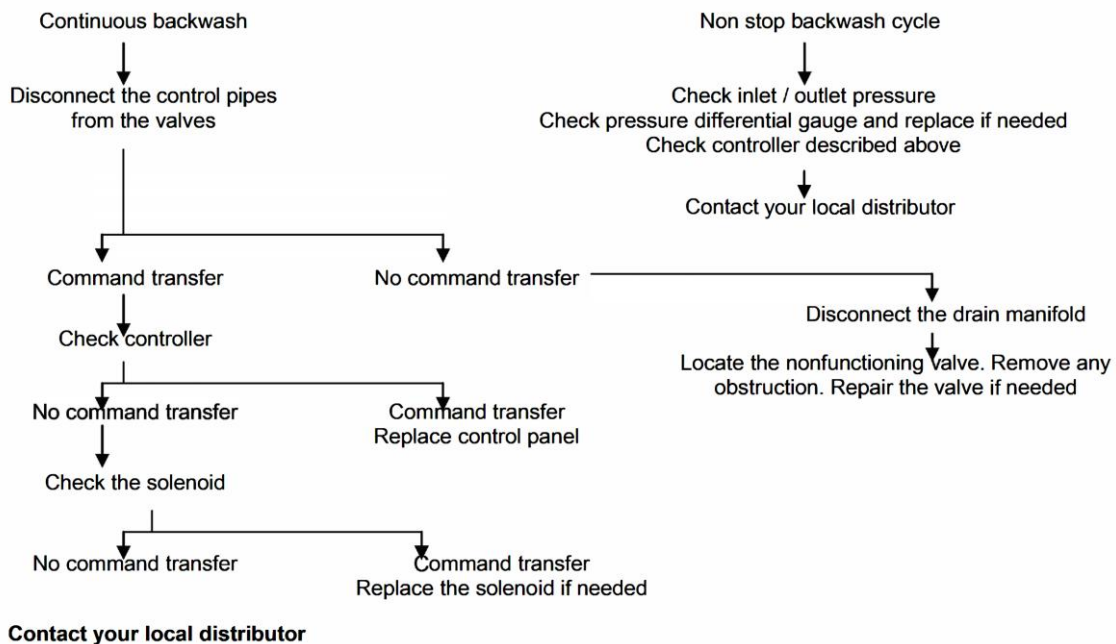

9. Parts Schedule

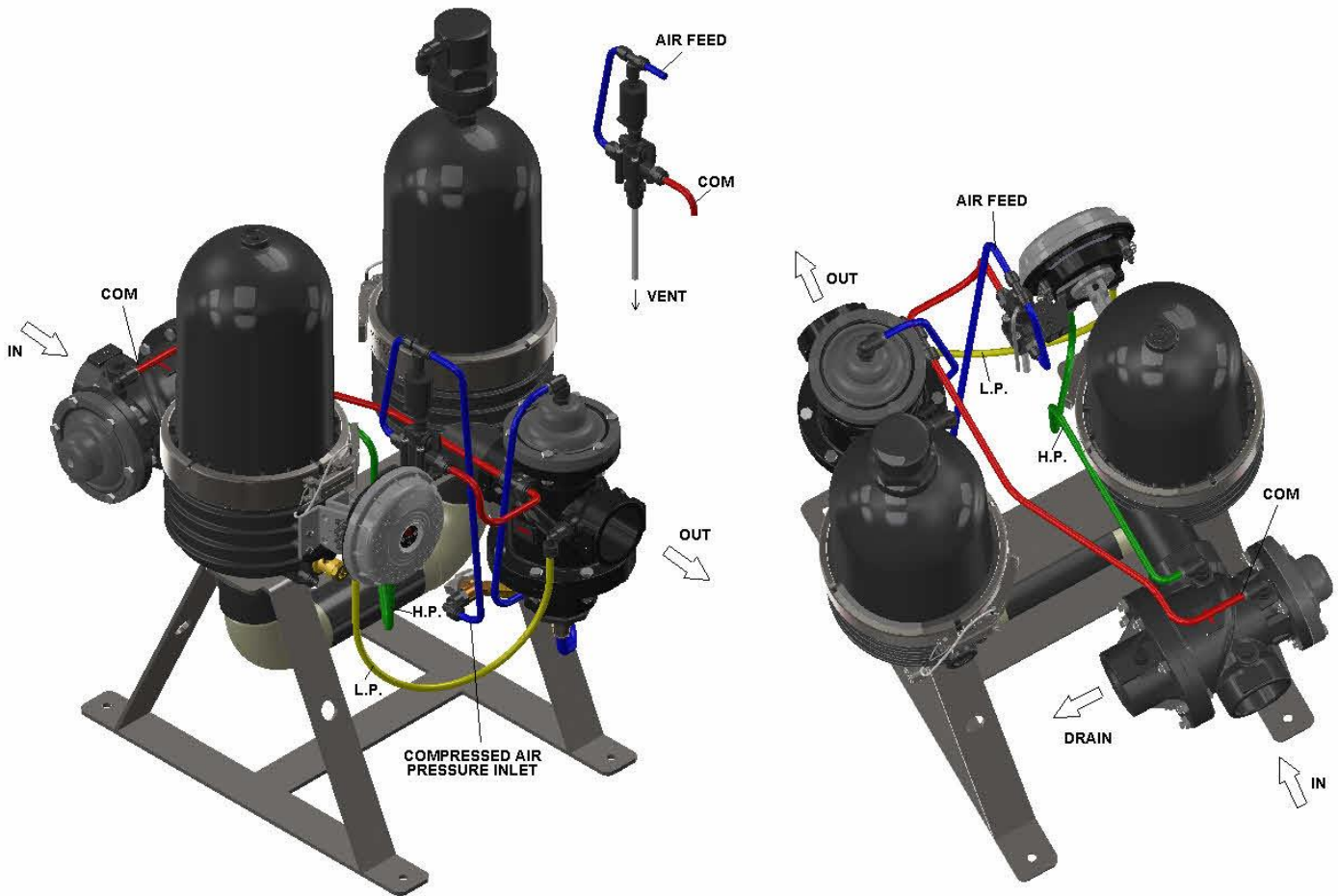

9.1 Parts List

No.	Description	SAP P/N
1	COVER 2"-3" FILTER RPA	710103-005233
	COVER 2"-3" FILTER RPP DW	710103-004798
	2"-3" COVER PC TRANSPARENT	710101-000899
2	HYDRAULIC SEAL 2"-3" EPDM	770104-000248
	HYDRAULIC SEAL 2" NBR 70 SHORE	770104-000251
	HYDRAULIC SEAL 2"-3" VITON 70 SHRE	770104-000001
3	FILTER CLAMP 2"-3" S/ST304	760108-000002
4	SPINE ASSEMBLY MODEL 2.8 2-3" SK RPA	700101-002255
	SPINE ASSEMBLY MODEL 2.8 2-3" SK RPA AW	700101-002258
	SPINE ASSEMBLY MODEL 2.8 2-3" SK RPA SW	700101-002259
	SPINE ASSEMBLY MODEL 2.8 2-3" SK RPP EPDM SEALS DW	700101-002257
	SPINE ASSEMBLY MODEL 2.8 2-3" SK RPA LCE	700101-002256
4.1	2"SK BUTTERFLY NUT RPA BLACK	710101-000435
4.2	2"SK SPINE TIGHTENING NUT RPA BLACK	710101-000106
4.3	SK 2.7 SPINE PISTON HDPE NATURAL DW	710101-000436
4.4	ANTI FRICTION S/ST316 F/2.7SK DW	760109-000045
	ANTI FRICTION SUPER DUPLEX F/2.7SK DW	760109-000467
4.5	CONE MEMBRANE NATURAL 65 SHORE	770104-000372
	CONE MEMBRANE EPDM 70 SHORE 2.7SPIN KLIN DW	770104-000375
	CONE MEMBRANE NATURAL 65 SHORE LCE 2.8 SPINE SK	770104-000384
4.6	PARKER O-RING 2-237 EPDM 70 SHORE YELLOW DOT	770102-000034
5	2"-3"SK DISC SET DW (130 MICRON)	700101-001176
6	DISC ELEMENT PP 130MIC 2-3" SK RPA	700101-002267
7	BODY 2" SK BATTERY RPA GRV	710103-006082
	BODY 2" SK BATTERY RPA BSPT	710103-006080
8	WRENCH GALVANIZED F/BUTTERFLY NUT	760109-000055

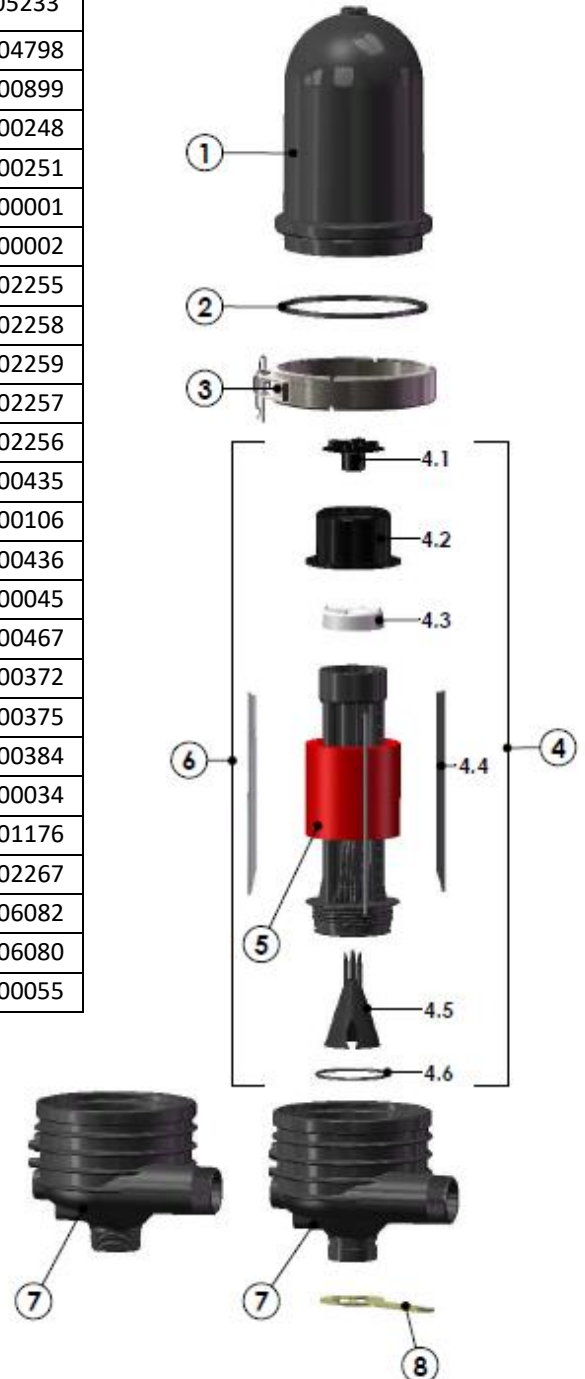

10. Valves - Parts Schedule and Parts List

350 Series Plastic Back-flush Filter Valve - Double Chamber Straight/Angle & Reverse Flow Size: 2"x2"

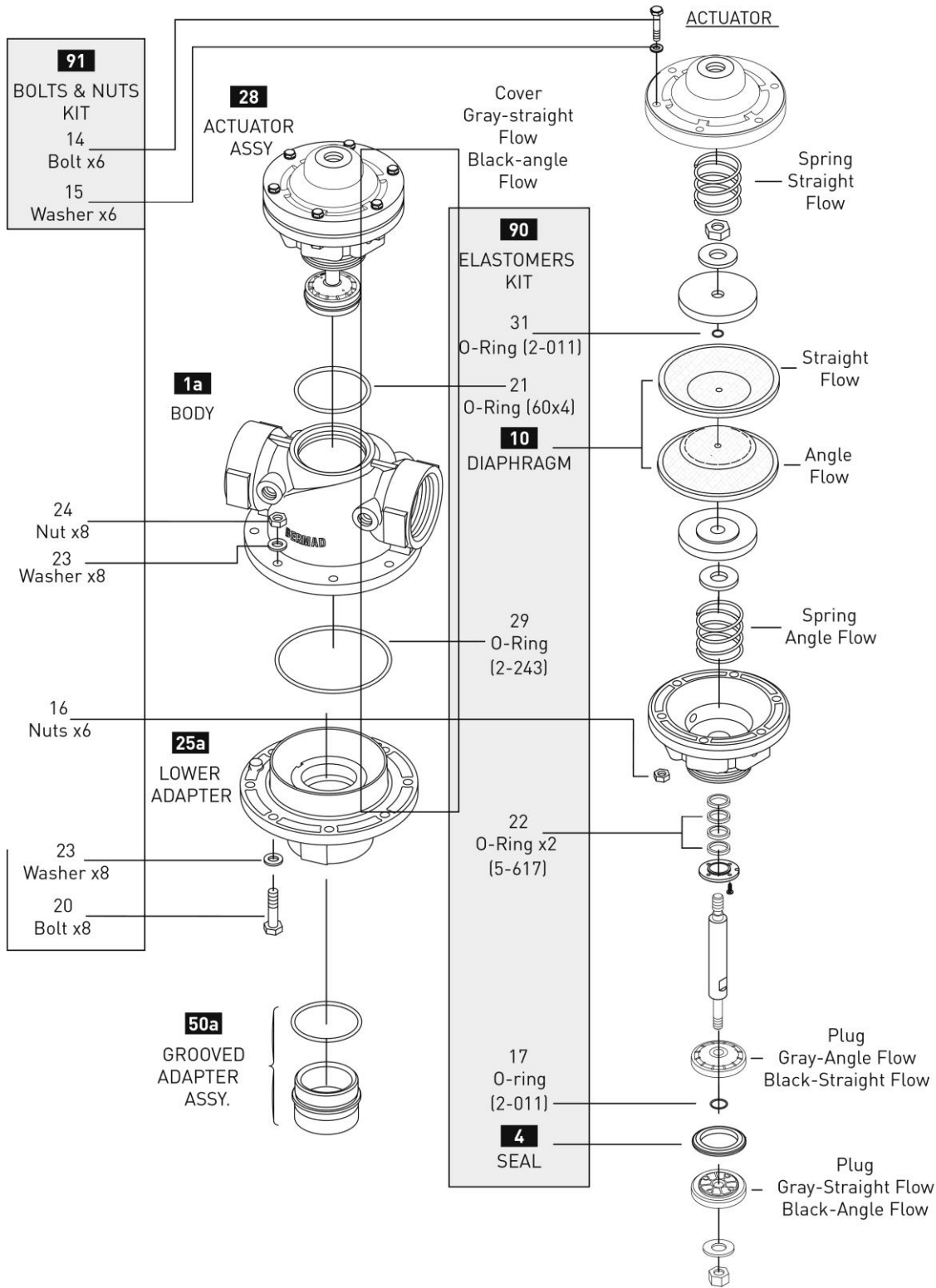

10.1 Standard Valves Parts List

STRAIGHT FLOW 2X2 350 BSP RPA BLACK BERMAD

730102-000169

No.	Description	SAP
1a	BODY ASSY. F/2" STRAIGHT FLOW BERMAD	730113-000317
25a	LOWER ADAPTOR F/2" STRAIGHT FLOW PLASTIC BERMAD	730113-000315
28	VALVE ASSY. F/2" STRAIGHT FLOW PLASTIC BERMAD	730113-000507
50a	2" GROOVED-BSP THREAD CONNECTOR ASSY	700190-003407
90	SEALS + DIAPHRAGM KIT F/2" 350 BERMAD	730113-000763
10	DIAPHRAGM F.2*2 VALVE	730113-000446
4	PLUG SEAL F.2*2PL.STR.VALVE	730113-000324
91	BOLTS-NUTS KIT F/2" 350 BERMAD	730113-000761

STRAIGHT REVERSE FLOW 2X2 350 BSP RPA BLACK BERMAD

730102-000173

No.	Description	SAP
1a	BODY ASSY. F/2" STRAIGHT FLOW BERMAD	730113-000317
25a	LOWER ADAPTOR F/2" STRAIGHT FLOW PLASTIC BERMAD	730113-000315
28	VALVE ASSY. F/2" STRAIGHT REVERSE FLOW PLASTIC BERMAD	730113-000338
50a	2" GROOVED-BSP THREAD CONNECTOR ASSY	700190-003407
90	SEALS + DIAPHRAGM KIT F/2" 350 BERMAD	730113-000763
10	DIAPHRAGM F.2*2 VALVE	730113-000446
4	PLUG SEAL F.2*2PL.STR.VALVE	730113-000324
91	BOLTS-NUTS KIT F/2" 350 BERMAD	730113-000761

10.2 DW Valves Parts List

STRAIGHT FLOW 2X2 350 BSP RPA BLACK BERMAD DW

730102-000283

No.	Description	SAP
1a	BODY ASSY. F/2" 350 BLACK PLASTIC BERMAD BSP DW	30113-000872
25a	LOWER ADAPTOR F/2" 350 BLACK PLASTIC BERMAD BSP DW	730113-000873
28	ACTUATOR ASSY. F/2" STRAIGHT FLOW PLASTIC BERMAD DW	730113-000871
50a	ADAPTOR+SEAL F/2" 350 BLACK PLASTIC BERMAD GRV/TRH DW	730113-000883
90	ELASTOMERS KIT F/2" 350 BERMAD DW	730113-000867
10	DIAPHRAGM F/2" STRAIGHT FLOW BERMAD	730113-000446
4	SEAL F/2" VALVE EPDM BERMAD DW	730113-000881
91	BOLTS-NUTS KIT F/2" 350 BERMAD	730113-000761

STRAIGHT REVERSE FLOW 2X2 350 BSP RPA BLACK BERMAD DW

730102-000284

No.	Description	SAP
1a	BODY ASSY. F/2" 350 BLACK PLASTIC BERMAD BSP DW	30113-000872
25a	LOWER ADAPTOR F/2" 350 BLACK PLASTIC BERMAD BSP DW	730113-000873
28	ACTUATOR ASSY. F/2" STRAIGHT REVERSE FLOW PLASTIC BERMAD DW	730113-000870
50a	ADAPTOR+SEAL F/2" 350 BLACK PLASTIC BERMAD GRV/TRH DW	730113-000883
90	ELASTOMERS KIT F/2" 350 BERMAD DW	730113-000867
10	DIAPHRAGM F/2" STRAIGHT FLOW BERMAD	730113-000446
4	SEAL F/2" VALVE EPDM BERMAD DW	730113-000881
91	BOLTS-NUTS KIT F/2" 350 BERMAD	730113-000761

10.3 AW Valves Parts List

STRAIGHT FLOW 2X2 350 BSP RPA BLACK AGRESSIVE WATER BERMAD

730102-000108

No.	Description	SAP
1a	BODY ASSY. F/2" 350 PLASTIC BERMAD WA	730113-000759
25a	LOWER ADAPTOR F/2" STRAIGHT FLOW PLASTIC BERMAD WA	730113-000332
28	VALVE ASSY. F/2" STRAIGHT FLOW PLASTIC BERMAD WA	730113-000331
50a	2" GROOVED-BSP THREAD CONNECTOR ASSY	700190-003407
90	SEALS + DIAPHRAGM KIT F/2" 350 BERMAD	730113-000763
10	DIAPHRAGM F.2*2 VALVE	730113-000446
4	PLUG SEAL F.2*2PL.STR.VALVE	730113-000324
91	BOLTS-NUTS KIT F/2" 350 BERMAD WA	730113-000762

STRAIGHT REVERSE FLOW 2X2 350 BSP RPA BLACK AGRESSIVE WATER BERMAD

730102-000115

No.	Description	SAP
1a	BODY ASSY. F/2" 350 PLASTIC BERMAD WA	730113-000759
25a	LOWER ADAPTOR F/2" STRAIGHT FLOW PLASTIC BERMAD WA	730113-000332
28	VALVE ASSY. F/2" STRAIGHT REVERSE FLOW PLASTIC BERMAD WA	730113-000345
50a	2" GROOVED-BSP THREAD CONNECTOR ASSY	700190-003407
90	SEALS + DIAPHRAGM KIT F/2" 350 BERMAD	730113-000763
10	DIAPHRAGM F.2*2 VALVE	730113-000446
4	PLUG SEAL F.2*2PL.STR.VALVE	730113-000324
91	BOLTS-NUTS KIT F/2" 350 BERMAD WA	730113-000762

10.4 SW Valves Parts List

STRAIGHT FLOW 2X2 350 BSP RPA/DUPLEX BLACK SW BERMAD

730102-000106

No.	Description	SAP
1a	BODY ASSY. F/2" 350 PLASTIC BERMAD WA-DUPLEX-S/S316	730113-000754
25a	LOWER ADAPTOR F/2" 350 PLASTIC BERMAD WA-DUPLEX-S/S316	730113-000753
28	ACTUATOR F/2" STRAIGHT FLOW BERMAD WA-S. DUPLEX	730113-000589
50a	2" GROOVED-BSP THREAD CONNECTOR ASSY	700190-003407
90	SEALS + DIAPHRAGM KIT F/2" 350 BERMAD	730113-000763
10	DIAPHRAGM F.2*2 VALVE	730113-000446
4	PLUG SEAL F.2*2PL.STR.VALVE	730113-000324
91	BOLTS-NUTS KIT F/2" 350 BERMAD WA	730113-000762

STRAIGHT REVERSE FLOW 2X2 350 BSP RPA/DUPLEX BLACK SW BERMAD

730102-000113

No.	Description	SAP
1a	BODY ASSY. F/2" 350 PLASTIC BERMAD WA-DUPLEX-S/S316	730113-000754
25a	LOWER ADAPTOR F/2" 350 PLASTIC BERMAD WA-DUPLEX-S/S316	730113-000753
28	ACTUATOR F/2" STRAIGHT REVERSE FLOW BERMAD WA-S.DUPLEX	730113-000590
50a	2" GROOVED-BSP THREAD CONNECTOR ASSY	700190-003407
90	SEALS + DIAPHRAGM KIT F/2" 350 BERMAD	730113-000763
10	DIAPHRAGM F.2*2 VALVE	730113-000446
4	PLUG SEAL F.2*2PL.STR.VALVE	730113-000324
91	BOLTS-NUTS KIT F/2" 350 BERMAD WA	730113-000762

11. System Drawings (to be amended per each specific ordered)

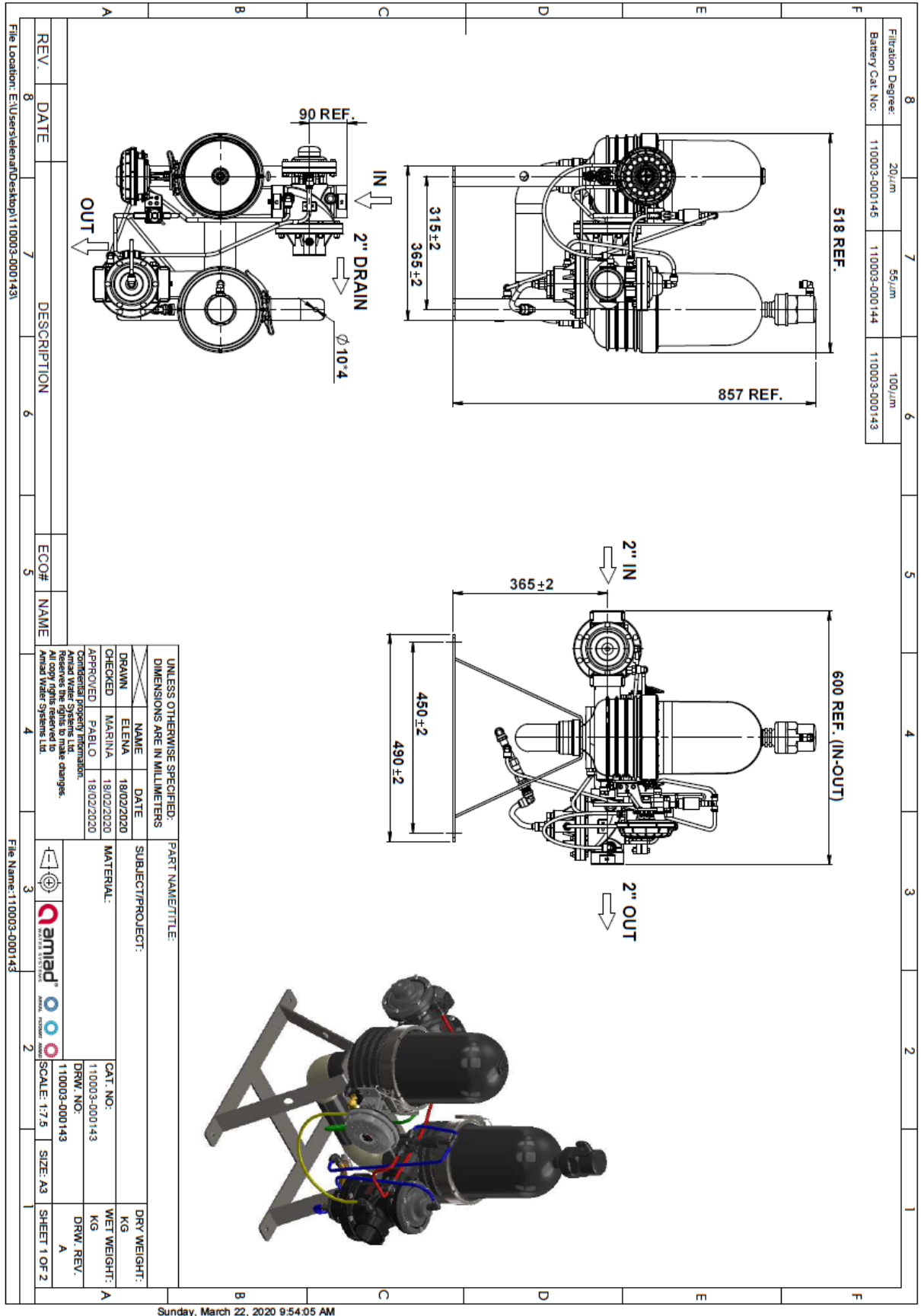

Sunday, March 22, 2020 9:54:05 AM

12. Amiad Limited Warranty

1. This certificate applies to Amiad Water Systems Ltd. ("**Amiad**") products purchased by you (the "**Buyer**") from Amiad unless specifically agreed otherwise in writing by Amiad. This Warranty extends only to the original purchaser, and is not transferable to anyone who subsequently purchases, leases, or otherwise obtains the product from the original purchaser.
2. Amiad hereby warrants that the products are and will be free from defects in material and workmanship under normal use and service. Amiad warrants that it will correct manufacturing defects in the products, in accordance with the conditions set out in this Warranty.
3. This Warranty is enforceable for a period of 12 months after the date upon which the products were delivered (the "**Warranty Period**").
4. In the event that during the Warranty Period the Buyer discovers a defect in material and/or workmanship in any product or part (the "**Defective Product**"), it shall submit a written complaint to Amiad using Amiad's standard Buyer Complaint Form. For the receipt of the Buyer Complaint Form, the submission of the complaint or any questions please contact your service representative.
5. Upon written demand by Amiad the Buyer shall return the Defective Product - or a sample thereof - to Amiad, at Amiad's cost. If the Buyer ships any such Defective Product, Amiad suggests the Buyer package it securely and insure it for value, as Amiad assumes no liability for any loss or damage occurring during shipment. Provided however that in the event Amiad determines that this Warranty does not apply to such product, Buyer shall promptly reimburse Amiad for such cost (including freight and customs). Any returned product or part must be accompanied by the Warranty certificate and the purchase invoice. It is clarified that the Buyer may not return the Defective Product unless such return was coordinated and approved by Amiad in advance.
6. Amiad's obligation under this Warranty shall be limited to, at Amiad's option, the repair or exchange, free of charge, of the product or any part which may prove defective under normal use and service during the Warranty Period. The provision of a repair or replacement of a product during the Warranty Period will result in an extension of the Warranty Period by an additional period of 12 months, provided that the total accumulated Warranty Period shall in any event be no more than 18 months from the date upon which the products were delivered.
7. This Warranty is valid on the condition that the products are installed according to Amiad's instructions as expressed in Amiad's instruction manuals and according to the technical limitations as stipulated in Amiad's literature or as stated by a representative of Amiad.
8. This Warranty will not apply to damaged or defective products resulting from or related to:
 - (i) Fire, flood, power surges or failures or any other catastrophe and/or unforeseen occurrence, such as but not limited to those for which the Buyer is customarily insured for, or any force majeure events;
 - (ii) Fault, abuse or negligence of the Buyer;
 - (iii) Intake water not meeting the agreed standards, as set forth in a written document, approved by Amiad, or improper storage;
 - (iv) Improper or unauthorized use of the product or related parts by the Buyer, including Buyer's failure to operate the product in conformity with the recommendations and instructions of Amiad, as set forth in Amiad's manuals and other written materials, the operation of the product other than by a trained and qualified operator, or improper installation of the product by a third party not authorized by Amiad;
 - (v) Performance by the Buyer of maintenance or operation other than in conformity with the recommendations and instructions of Amiad, or other than in accordance with procedures defined in the literature supplied for products (including the timely replacement of requisite parts), and for services provided other than by a trained and qualified advanced operator; or
 - (vi) Any alteration, modification, foreign attachment to or repair of the products, other than by Amiad or its authorized technical representatives.
9. In no event shall Amiad be liable to the Buyer or any third party for any damages to property, or for any intangible or economic loss, including loss of profits, loss of customers or damage to reputation, for any damages, including indirect, special, consequential damages, or punitive damage arising out of or in connection with this Warranty, or arising out of or in connection with the product's performance or failure to perform, even if it has been advised of the possibility of such damages.
10. Amiad will be excused for failure to perform or for delay in performance hereunder if such failure or delay is due to causes beyond its reasonable control or force majeure preventing or hindering performance.
11. This Warranty set forth herein is the only contractual warranty given by Amiad and is provided in lieu of any other warranties created by any documentation, packaging or otherwise.
12. Amiad makes no warranty whatsoever in respect to accessories or parts not supplied by Amiad. In the event that Amiad is required to correct a Defective Product or product not covered by this Warranty, it will do so solely in consideration for additional fees.
13. The parties will actively endeavor to amicably settle any dispute arising between them. In the event that the parties are unable to reach an equitable settlement of such dispute, any claim or lawsuit related to the Warranty, its validity execution, its performance be brought before only the courts of Tel-Aviv, Israel. Israeli law will govern the Warranty, to the exclusion of any conflict of law rules.