

Arkal 2" Sand Separator Hydro Cyclone

Catalog No. 1218 _ _ _ _

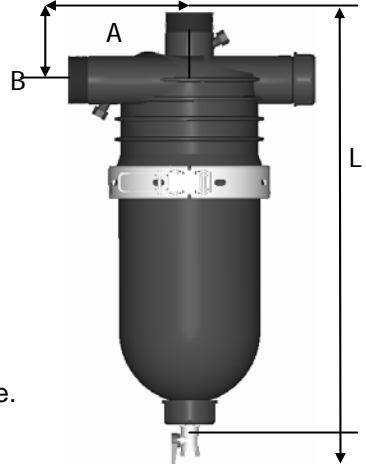

- The unit is mounted in a vertical position.
- Water enters through the tangential inlet producing a downward spinning movement. Sediments are pressed against the filter body by centrifugal force.
- Sediments accumulate at the bottom of the filter.
- In order to flush accumulated sediments, a drain valve is installed at the bottom of the unit.

Applications

- Sand and gravel separation from deep well pumping.
- Pre-filtering of water supplied to laboratories and industry.
- Pre-filtering of drip and micro-sprinkler systems.
- Protective sand removal – prevents wear and tear on sprinkler nozzles.

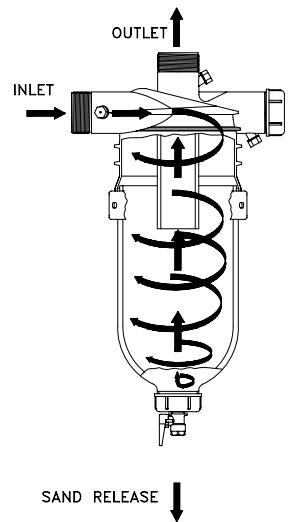

Technical Data

Inlet/outlet diameter	2" BSPT (male)	2" (male)
	50 mm – nominal diameter	
Maximum pressure	12 atm	168 psi
Maximum flow rate	25 m ³ /h (7 l/sec)	110 gpm
Minimum flow rate	15 m ³ /h (4 l/sec)	66 gpm
Weight	5.15 kg	10.4 lbs.
Sand drainage	20mm thread	¾" thread
Distance between inlet end outlet	A. 145mm B. 85mm	A. 5 ²³ / ₃₂ " B. 3 ¹ / ₃₂ "
Filter length	560mm	22 ¹ / ₈ "

Head Loss (metric standard)

Head Loss (U.S. standard)

Flow rate cu. m ³ /h	15	20	25	Flow rate gpm	60	80	100
Head loss meter	3.7	7.0	11.4	Head loss psi	4.2	8.4	12.8

Installation

The Sand Separator may be installed as a single unit or in batteries.

3/4" drain valve must be installed at the bottom of the cover and either manually or hydraulically controlled.

It is highly recommend to install a disc filter after the hydro cyclone to stop organic material.

Periodically open the drain valve so that the sediments can flow out.

Separation Efficiency (%)

Flow Rate	Particle size larger than (μ)		
	150	100	50
15	97	94	82
20	98	97	85
25	99	98	90

Parts List

No.	Cat. No.	Description	Materials
1	2511 0103	Gauge port nut	RPP
2	5006 0004	Gauge port seal	EPDM
3	2511 0200	2" Cap	RPP
4	5020 0051	2" Nipple	PVC
5	5042 0030	Clamp	SS
6	5005 0002	Hydraulic seal	EPDM
7	5006 0022	Erosion preventer	NR
8	2501 0222	Cover	RPA
9	2253 0230	Sand accumulator	
10	5054 0013	3/4" Tap	BRASS
11	2250 0230	Sand accumulator complex	
12	2202 0226	Cover complex	
13	2218 0002	Body complex threaded ends	

Materials

RPP - REINFORCED POLYPROPYLENE

RPA - REINFORCED POLYAMIDE

SS - STAINLESS STEEL

NR - NATURAL RUBBER

